

# High-Performance Multi-Point Mass Flow Meter System For Large Ducts & Stacks

## Features

- Innovative and user-friendly HMI offers advances over industry- standard collector boxes and allows users to:
  - Average the flow of 2-4 meters (and removes meters from the average under alarm or user selected conditions)
  - Convert flow units
  - Set up the density of the gas for mass flow measurement
  - Easily configure the individual meters
  - Set up alarms
- Unique multiple transmitter approach allows individual points to be removed for service or repair without shutting down the system and allows users the ability to compensate for swirl
- Direct mass flow monitoring eliminates the need for separate temperature and pressure inputs
- Accuracy +/- 1 % of reading plus 0.5% of full scale
- Patented Dry-Sense™ technology eliminates sensor drift
- State-of-the-art calibration facility ensures a highly accurate calibration that matches the application
- High temperature option to 750 °F (400 °C) available
- Low pressure hot taps available

**SIERRA**<sup>®</sup>  
**INSTRUMENTS**  
THE MASS FLOW COMPANY

ISO  
REGISTERED  
9001

# Multi-Trak™ Model 670S

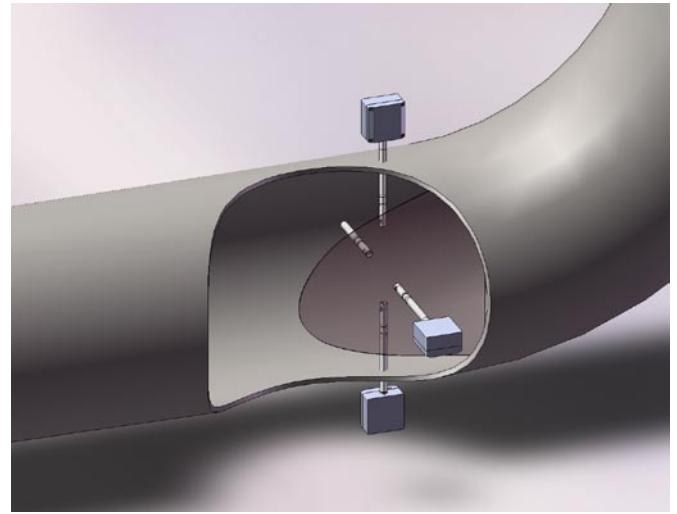

## Description

**S**ierra's Multi-Trak™ Model 670S is an advanced state-of-the-art instrument for measuring mass flow rates in very large ducts or stacks that have non-uniform velocity profiles, high turn-down requirements, dirty gas streams, wide temperature ranges and fast velocity and temperature changes. The Multi-Trak™ dynamically compensates for changes in the flow profile by using up to four independent mass flow sensing points to measure the instantaneous average gas mass flow velocity. The Multi-Trak™ is commonly used in petrochemical refining, coal-fired electric power generation, steel manufacturing and many other industrial processes that face the challenge of accurate and repeatable gas mass flow measurement in very large pipes or ducts.

An innovative, versatile and user-friendly microprocessor-based Human Machine Interface (HMI) controls all functions of the Model 670S system. The HMI is used to collect, visualize and store flow data, as well as set up the individual sensor points, thus allowing the entire system to be easily configured in the field. The Multi-Trak™ HMI integrates the functions of flow measurement, flow-range adjustment, field validation and diagnostics, and displays mass flow rate and totalized flow, as well as other configuration variables. All of this data is easily programmable from the HMI's easy-to-use touch screen.

The Multi-Trak™ system has major advantages over other multipoint systems. Unlike single probe insertion sensors where each sensor point is on the same insertion probe, each Multi-trak™ sensor point is completely independent of the others, allowing for easy field swap-out or cleaning of individual transmitters. Because of this, Multi-trak™ sensors do not have to be located on the same plane, and can be positioned to eliminate the effects of swirl.

## Hazardous-Area Location Enclosure Dimensional Specifications

### Compression Fitting—Side View (E2)

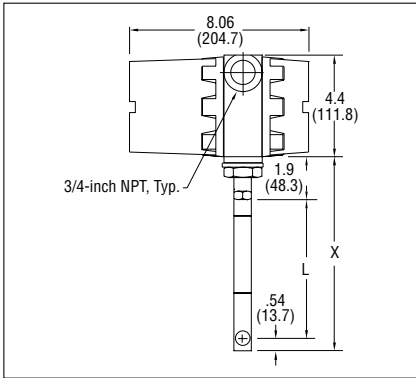

### Compression Fitting—Front View (E2)

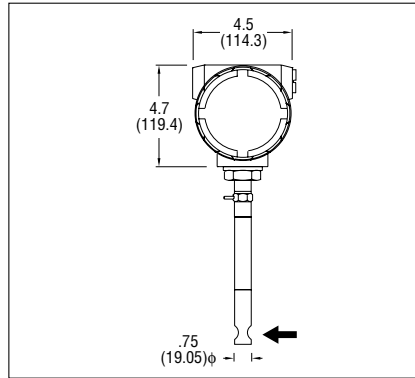

### Remote Mount Junction Box—Side View (E4)

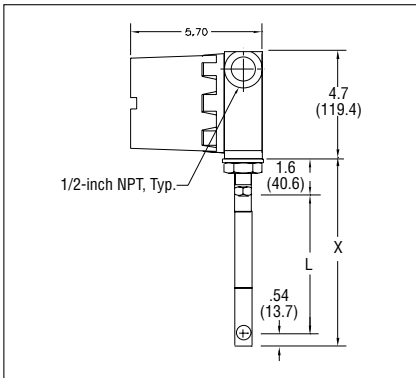

### Remote Mount Junction Box—Front View (E4)

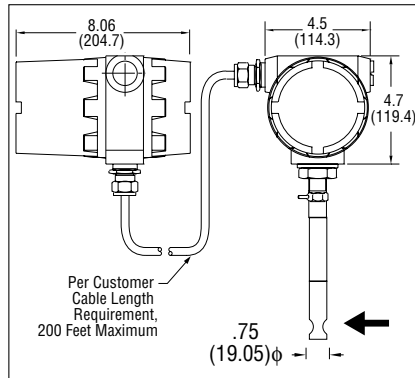

## Tables

Length Chart (Compressions Fittings)		
Code	L	X
L06	6.0 (152.4)	7.5 (190.5)
L09	9.0 (228.6)	10.5 (266.7)
L13	13.0 (330.2)	14.5 (368.3)
L18	18.0 (457.2)	19.5 (495.3)
L24	24.0 (609.6)	25.5 (647.7)
L36	36.0 (914.4)	37.5 (952.5)

Length Chart (Remote Mount Junction Box)		
Code	L	X
L06	6.0 (152.4)	7.5 (190.5)
L09	9.0 (228.6)	10.5 (266.7)
L13	13.0 (330.2)	14.5 (368.3)
L18	18.0 (457.2)	19.5 (495.3)
L24	24.0 (609.6)	25.5 (647.7)
L36	36.0 (914.4)	37.5 (952.5)

## NEMA 4X Dimensional Specifications

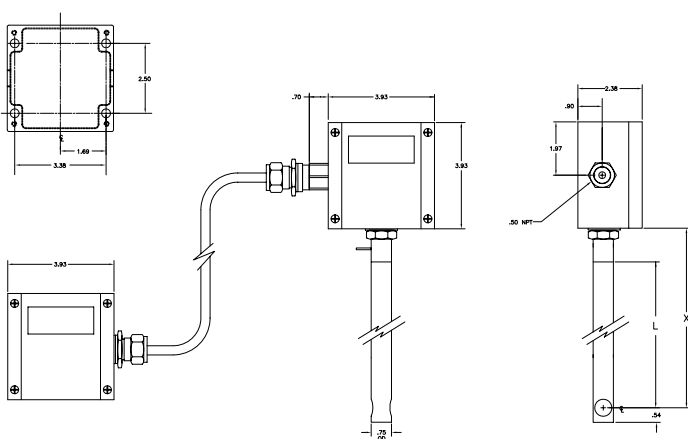

## NEMA 4X Representative Array

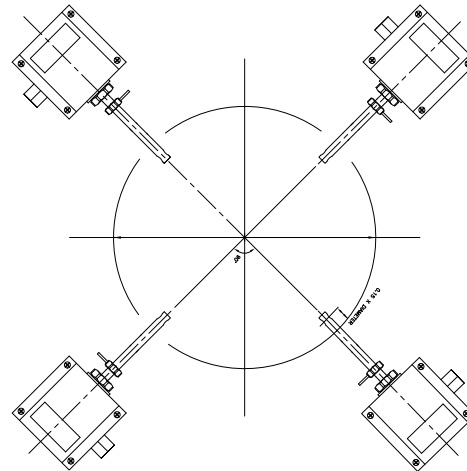

## Representative Daisy Chaining Units

4 WIRE CABLE, POWER AND COMMUNICATION

DAISY CHAINING THE UNITS

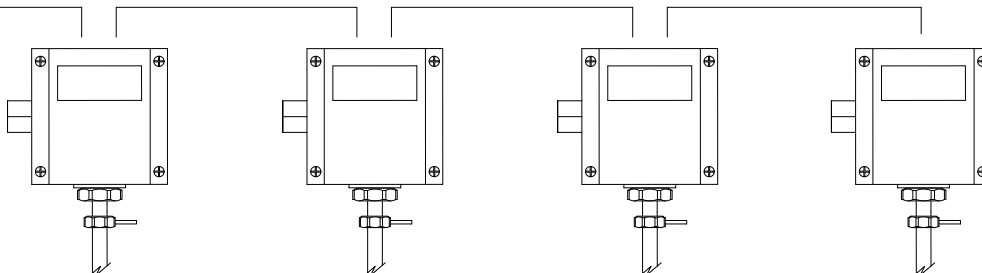

## Performance Specifications

### Accuracy of Point Velocity

+/- 1% of reading + 0.5% of full scale

### Repeatability

+/- 0.2% of full scale

### Temperature Coefficient

+/- 0.02% of reading per °F within +/- 50° F of customer specified conditions

+/- 0.03% of reading per °F within +/- 50° F to 100° F of customer specified conditions

+/- 0.04% of reading per °C within +/- 25° C of customer specified conditions

+/- 0.06% of reading per °C within +/- 25° C to 50° C of customer specified conditions

### Pressure Coefficient

.02% per psi for air, consult factory for other gases

### Response Time

One second to 63% of final velocity value

## Operating Specifications

### Gases

Most gases compatible with 316 L stainless steel

Hastalloy® available

### Gas Pressure

Mechanical design pressure:

Compression fittings: 500 psig (34 barg)

1-inch 150 lb flange (-40° to 250° F): 185 psig (12.8 barg)

Low Pressure Hot Tap: 150 psig (10 barg)

High Pressure Hot Tap: 1000 psig (70 barg)

### Pressure Drop

Negligible for pipes three inches in diameter or larger

### Gas & Ambient Temperature

Gas ..... -40° F to 350° F (-40° C to 177° C) Gas dependent.

Ambient ..... -40° F to 120° F (-40° C to 50° C)

Optional: Up to 750° F (400° C) air only; consult factory for other gases

### Leak Integrity

5 x 10<sup>-9</sup> cc/sec of helium maximum

### Power Requirements

18 to 30 VDC (regulated), 825 mA per point

The HMI includes probe power supplies

Note that only DC powered 640S meters can be used with the multipoint

### Output

Linear 4-20 mA proportional to grand-average flow signal

## HMI



## Physical Specifications

### Wetted Materials

316L stainless steel

### Enclosure

Hazardous-Area Location Enclosure (IP66) or NEMA 4X (IP65)

Both are powder-coated cast aluminum

### Electrical Connections

Two 3/4 inch NPT: Hazardous-Area Location Enclosure (IP66)

One 1/2 inch NPT: NEMA 4X Enclosure (IP65)

### Mounting (optional)

ANSI 1-inch 150 lb flange

3/4-inch tube compression fitting with 1-inch male NPT

Hot tap systems

### Certifications

CE (All enclosures)

CSA (Explosion proof for Class I, Division 1, Groups B, C, D)

ATEX (II 2 GD Ex d IIC T6 ... T2; IP 66 ... T70 °C ... T280 °C)

FM (Explosion proof for Class I, Division 1, Groups B, C, D; dust-ignition

proof for Class II, III, Division 1, Groups E, F, G)

IP65, NEMA 4X T6 -40° C to 70° C ambient

Chinese pattern approval

GOST R/RTN (1ExdIICT6...T2)

## HMI Settings

Units: Set flow units of grand-average flow rate

Density: Set gas density

Average: Set which units contribute to the grand-average

Output: Setup 4-20mA output for the grand-average

Pipe ID: Set Pipe ID

Alarm: Set low or high flow alarm for individual meters

(will be removed from the grand-average flow rate under alarm conditions)

### Advanced:

Allows setting of K factors, User full scale and K factors for individual meters

Gives meter setup information

### HMI Equation for Grand-Average flow

$$\text{Average} = \left( \frac{X1 * \text{Flow1} + X2 * \text{Flow2} + X3 * \text{Flow3} + X4 * \text{Flow4}}{4} \right) * K_{tot}$$

Where:

X1 to X4: individual flow meter weighting factor

(allows users to adjust the contribution of each individual meter to the grand-average flow rate)

Flow1 to Flow4: individual point flow rate

Xtot: Overall K-factor for grand-average flow

Average: the grand-average flow rate

## Ordering the Model 670S

**First specify the Individual 640S Flow Meters: (i.e. 4x670S-NAA-L13-M1-EN2-P2-V4-NR-0-MB-HT)**

<b>PARENT MODEL NUMBER</b> 670S Multi-Trak™ Immersible Thermal Flow Meter	670S					P2-V4-NR		MB	
<b>AGENCY APPROVALS</b> <b>NAA</b> Non-Agency Approved Meter <b>CSA</b> Explosion Proof for Class I, Division 1, Groups B, C, D <b>ATEX</b> II 2 GD Ex d IIC T6 ... T2; IP 66 T70 °C ... T280 °C <b>FM</b> Explosion Proof for Class I, Division 1, Groups B, C, D									
<b>PROBE LENGTH</b> <b>L06</b> 6-inches (15 cm) <b>L09</b> 9-inches (23 cm) <b>L13</b> 13-inches (33 cm) <b>L18</b> 18-inches (46 cm) <b>L24</b> 24-inches (61 cm) <b>L36</b> 36-inches (92 cm) <b>L(in)</b> Special Length (Length in Inches)									
<b>MOUNTING ACCESSORIES</b> <b>640S-M0</b> None <b>640S-M1</b> Compression Fitting (3/4-inch tube x 1-inch Male NPT) <b>640S-M2 ( )</b> Threadolet (3/4-inch Female NPT) Specify pipe O.D. in parentheses <b>640S-M3</b> Flat Duct Bracket (3/4-inch tube compression fitting) <b>640S-M4 ( )</b> Curved Duct Bracket (3/4-inch tube compression fitting) Specify duct O.D. in parentheses <b>640S-M8 ( )</b> Low Pressure Hot Tap. Specify duct O.D. in parentheses <b>640S-M15 ( )</b> Quick Removal Tap. Maximum 40 psig (2.8 barg)									
<b>ENCLOSURES</b> <b>E2</b> Hazardous-Area Location Enclosure <b>E4(ft)</b> Remote Hazardous-Area Location Enclosure with Junction Box <b>EN2</b> NEMA 4X <b>EN4(ft)</b> Remote NEMA 4X with Junction Box Specify Cable Length in Parentheses									
<b>P2-V4-NR</b> 24VDC, 4-20mA, No Display									
<b>GAS CODE</b> <b>0</b> Air <b>99</b> Other									
<b>MODBUS Communications</b>									
<b>OPTION (HIGH TEMPERATURE)</b> <b>HT</b> To 750 °F (400 °C); Requires E4, EN4 remote option.									

## Ordering the Model 670S HMI

**HMI System with Multipoint 640S: (i.e. 4x 670S-H01-G08-B05-SW-P2 ( ) -V4 ( ) -DC ( ) -MASTER ( ) )**

<b>H01</b>	<b>G08</b>	<b>B05</b>	<b>SW</b>	<b>P2 ( )</b>	<b>V4 ( )</b>	<b>DC ( )</b>	<b>MASTER ( )</b>				
<table border="1" style="width: 100%; border-collapse: collapse;"> <tr> <td style="width: 30%;"><b>HMI ELECTRONICS</b>  <b>H01</b> HMI, Monochrome screen 12 x 5 cm, Touch Screen Panel  <b>G08</b> IO-8All - 8 current inputs - 0-20 mA/ 4-20 mA  <b>B05</b> Aluminum housing (IP65)  <b>SW</b> Software, programming HMI           </td> <td style="width: 70%;"></td> </tr> <tr> <td><b>CABLING</b>  <b>P2</b> DC power cable to the HMI with flyleads (specify length in ft). Note the HMI supplies the individual meters  <b>V4</b> 4-20mA output cable (grand-average signal from HMI). Specify length in ft  <b>DC</b> Individual cabling to daisy chain each meter (this will be 3 cable sets for a 4 point system) Specify Length in ft. We recommend (1.5x the pipe circumference)/3 or 1.6x the pipe diameter  <b>MASTER</b> last link of the daisy chain from meter to HMI (specify length in ft)           </td> <td></td> </tr> </table>								<b>HMI ELECTRONICS</b> <b>H01</b> HMI, Monochrome screen 12 x 5 cm, Touch Screen Panel <b>G08</b> IO-8All - 8 current inputs - 0-20 mA/ 4-20 mA <b>B05</b> Aluminum housing (IP65) <b>SW</b> Software, programming HMI		<b>CABLING</b> <b>P2</b> DC power cable to the HMI with flyleads (specify length in ft). Note the HMI supplies the individual meters <b>V4</b> 4-20mA output cable (grand-average signal from HMI). Specify length in ft <b>DC</b> Individual cabling to daisy chain each meter (this will be 3 cable sets for a 4 point system) Specify Length in ft. We recommend (1.5x the pipe circumference)/3 or 1.6x the pipe diameter <b>MASTER</b> last link of the daisy chain from meter to HMI (specify length in ft)	
<b>HMI ELECTRONICS</b> <b>H01</b> HMI, Monochrome screen 12 x 5 cm, Touch Screen Panel <b>G08</b> IO-8All - 8 current inputs - 0-20 mA/ 4-20 mA <b>B05</b> Aluminum housing (IP65) <b>SW</b> Software, programming HMI											
<b>CABLING</b> <b>P2</b> DC power cable to the HMI with flyleads (specify length in ft). Note the HMI supplies the individual meters <b>V4</b> 4-20mA output cable (grand-average signal from HMI). Specify length in ft <b>DC</b> Individual cabling to daisy chain each meter (this will be 3 cable sets for a 4 point system) Specify Length in ft. We recommend (1.5x the pipe circumference)/3 or 1.6x the pipe diameter <b>MASTER</b> last link of the daisy chain from meter to HMI (specify length in ft)											