

Ultrasonic Flowmeter Instruction Manual

Model: SL1168

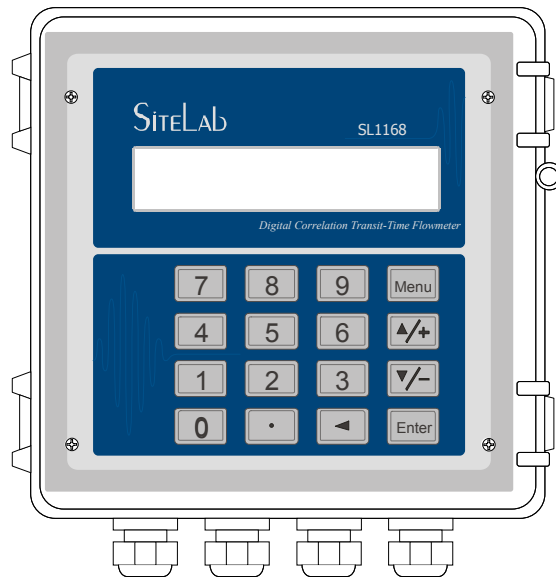

SITELAB

Edition: 1.0.2

Date: Oct. 2009

Update Record	Revision	
	Date	

Notice

Thank you for choosing the SL1168 Ultrasonic Flowmeter with SLSI CMOS and low-voltage wide-pulse sending technology.

This instruction manual contains important information. Please read carefully before the operation of the flowmeter.

This instruction manual will introduce how to use the flowmeter step-by-step, including product component, installation, wiring, quick setup etc. to make it easier to operate.

Understanding more about the menu settings can fulfill your higher requirements with the flowmeters' powerful function option and output function.

**Warning**

May cause injury.





**Attention**

May damage the flow meter.

Some of the instructions may differ to the flowmeters you purchased, depending on configuration requirements at the time of purchasing or the change of the product design and upgrade requirement. There is no indication in the instructions, please refer to the version number, as well as the appendix.

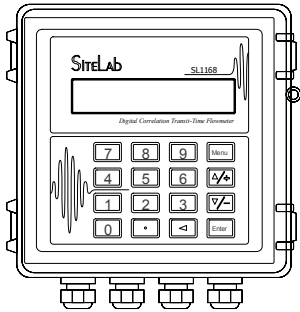
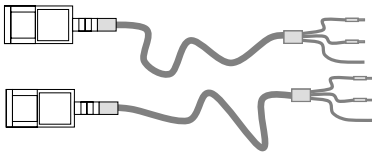
Product Component

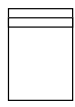
Inspection should be made before installing the Flowmeter. Check to see if the spare parts are in accordance with the packing list. Make sure that there is no damage to the enclosure due to a loose screw or loose wire, or other damage that may have occurred during transportation. Any questions, please contact your representative as soon as possible.

Transmitter	Transducer
	
Accessory	Document
 <p>Pipe Strap</p>  <p>Coupling compound</p>  <p>Install accessory</p>	 <ol style="list-style-type: none"> 1. Instruction Manual 2. Packing List 3. Position drawing

Content

1. Transmitter Installation and Connect	7
1.1. Inspection prior to Transmitter Installation.....	7
1.2. Wire Connecting.....	7
1.2.2. Lengthened Cable Method.....	8
1.2.3. Sketch of lengthened Cable	8
1.2.4. Junction Box Requirements	8
1.2.5. Cable Specifications	8
1.3. Powering on	9
1.4. Keypad Functions.....	9
1.5. Keypad Operation.....	9
1.6. Flowmeter Window Descriptions	10
2. Pipe Parameter Entry Shortcuts	11
3. Measurement Site Selection	12
4. Transducer Installation	15
4.1 Installing the transducers	15
4.1.1 Transducer spacing	15
4.1.2 Transducer Mounting Methods.....	15
4.1.3 V Method	15
4.1.4 Z Method	16
4.1.5 N Method (not commonly used).....	16
4.1.6 W Method (very rarely used).....	16
4.2 Transducer Mounting Inspection	17
4.2.1 Signal Strength.....	17
4.2.2 Signal Quality (Q value).....	17
4.2.3 Total Time and Delta Time	17
4.2.4 Transit Time Ratio	18
5 . Operating Instructions	20
5.1 System Normal Identification.....	20
5.2 Zero Set Calibration.....	20
5.3 Scale Factor	20
5.4 System Lock (Unlock).....	21
5.5 4~20mA Current Loop Verification (Optional)	21
5.6 Frequency Output	21
5.7 Totalizer Pulse Output	22
5.8 Alarm Programming.....	22

5.9 Recover the Factory Default 22

5.10 4~20mA Analog Output Calibration 22

5.11 ESN..... 23

6. Windows Display Explanations 24

6.1. Windows Display Codes 24

6.2 Display explanation 27

7. Error Diagnoses 53

7.1 Table 1. Self-diagnoses and error solutions (upon power on)..... 53

7.2 Table 2. Error codes and solutions (during operation)..... 54

7.3 Frequently Asked Questions and Answers..... 55

8 Product Overview 41

8.1 Introduction 41

8.2 Features of SL1168..... 41

8.3 Theory of Operation 41

8.4 Specifications..... 42

9 Appendix1 - Serial Interface Network Use and Communications Protocol 43

9.1 Overview 43

9.2 Serial port definitions 43

9.3 Direct connection via RS232 to the host device 45

9.4 Communication protocol and the use 45

9.4.1 Basic commands 45

9.4.2 Function prefix and function sign 46

9.4.3 Modbus Protocol..... 47

10 Appendix2-Energy Meter—RTD Module and PT100 Wiring (Module optional) 49

10.1 RTD Energy Meter Function 49

10.2 Wiring..... 50

10.3 Energy Measurement Methods 50

10.4 Temperature Range Adjustment..... 51

10.5 RTD Module Calibration Methods 51

Update Information:

1. Transmitter Installation and Connect

1.1. Inspection prior to Transmitter Installation

You will find a “Position Drawing” in the packing. Please use it as a template in the place that you are going to install the Flowmeter. Then drill 4 installing holes at the screws position shown on the drawing with the 5.5mm drill.

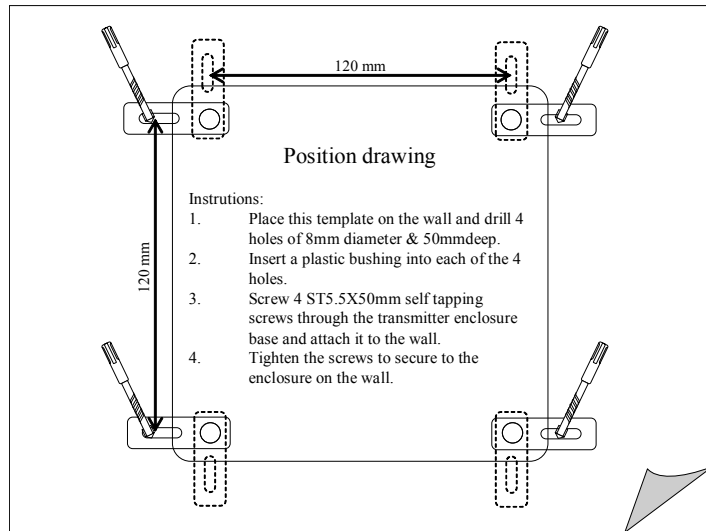

Take out the enclosed screws and plastic bushings. Insert the plastic bushings into the installing holes. Brackets will be installed at the bottom of the flowmeter. Put the flowmeter to the position and screw it in.

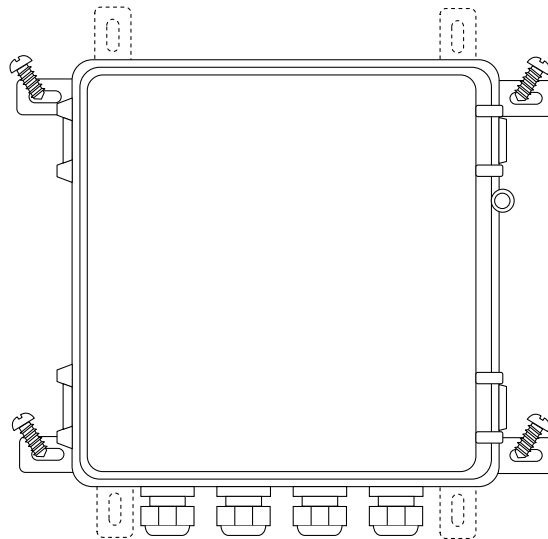

Attention

When installing please ensure the front cover is secure and will not fall open.

1.2. Wire Connecting

1.2.1. Power supply option

Customers should pay special attention to specify the desired power supply when wiring.

Factory standard power supply is 10~24VAC or 10~36VDC/1A max.

To ensure the transmitter can work normally, please pay attention to the followings when wiring:

Ensure that power connections are made in accordance with the specifications shown on the transmitter.

1.2.2 Transmitter wiring

Once the electronics enclosure has been installed, the Flowmeter wiring can be connected.

Open the case, you will find the transmitter interfaces labels from left to right as follows:

Power supply, Relay output, OCT Output, Downstream transducer, Upstream transducer, 4-20mA, RS232 interface.

Refer to the below diagram for specific connection:

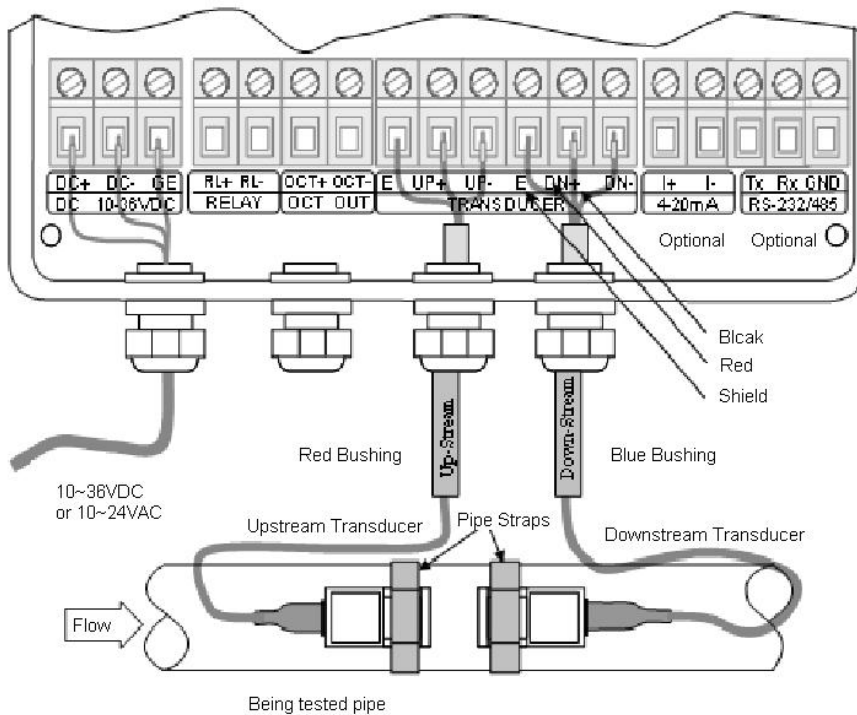

1.2.2. Lengthened Cable Method

Standard cable length of sensor is 9 meters; it can be lengthened to be 300 meters according to the actual need for fluid measurement.

1.2.3. Sketch of lengthened Cable

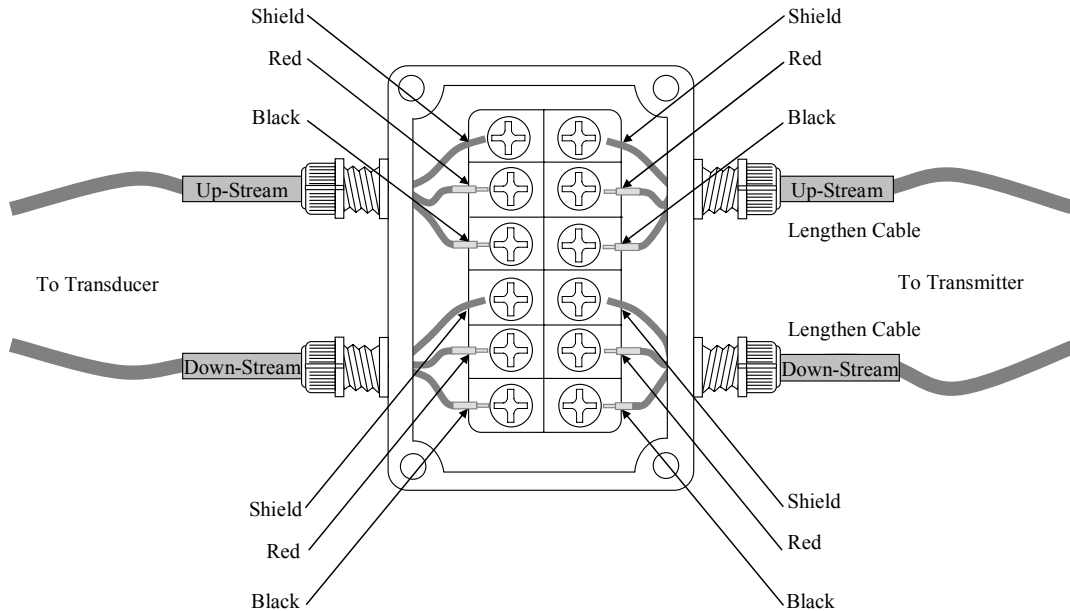

1.2.4. Junction Box Requirements

The flowmeter use sealed waterproof junction box, installing 6×2 press-connections, the recommended minimum specifications of the junction box is 115×90×55mm.

1.2.5. Cable Specifications

- Name: Shielded Twisted Pair
- Administer Standard: JB8734.5-1998
- Diameter: $\Phi 5$ mm
- Twist Line Space: 50 mm
- Multi Core Line: $0.4 \text{ mm}^2/\text{radix}$
- Guage: AWG 20#
- Core Line Color: Red and Black
- Shield Floor: 128 Intwine



Warning

Wire with power off. The flow meter must be reliable grounding before installation.

1.3. Powering on

As soon as the Flowmeter is switched on, the self-diagnosis program will start to run. If any error is detected, an error code will display on the screen (Refer - Error Diagnoses). After that self-diagnosis, the system will run automatically according to the last input parameters.

If the installation is accomplished when system is switched on, gain adjustment can be monitored in Window M01. After S1, S2, S3, S4 are displayed on the upper left corner of the screen, the system will activate the normal measurement condition automatically. It is indicated by code “*R” on the upper left corner of the screen.

If it is the first use or install on a new site, the customer need to input the new installation site parameters. The system will default to the last window settings and automatically display them at next power on.

1.4. Keypad Functions

Follow these guidelines when using the Flowmeter keypad (Refer to Keypad Figure):

- ⓪ ~ ⑨ And ◉ To input numbers.
- ⏪ Backspace or delete characters to the left.
- ⬆/+ And ⬇/- Return to the last menu or to open the next menu. Acts as “+” and “-” functions when entering numbers.
- Ⓜ Select a menu. Press this key first, input two menu numbers and then enter the selected menu. For example, to input a pipe outside diameter, press Ⓜ①① keys, where “11” is the window ID to display the parameter for pipe outside diameter.

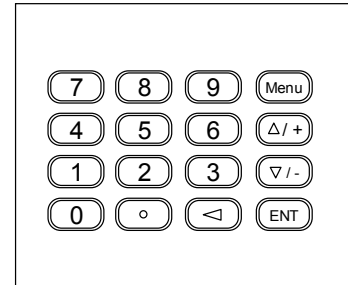

1.5. Keypad Operation

The flow meter adopts the window software design to consolidate or subdivide all of the parameters entered, the instrument setup and measurement result displays into more than 100 independent windows. The operator can input parameters, modify settings or display measurement results by “visiting” a specific window. These windows are arranged by 2-digit serial numbers (including “+” sign) from 00~99, then to +0, +1, etc. Each window serial number, or so-called window ID code, has a defined meaning. For example, Window M11 indicates the parameter input for pipe outside diameter, while Window M25 indicates the mounting spacing between the transducers, etc. (Refer – Windows Display Explanations).

The keypad shortcut to visit a specific window is to press the Ⓜ key at any time, then input the 2-digit window ID code. For example, to input or check the pipe outside diameter, just press the Ⓜ①① keys for window ID code 11.

Another method to visit a particular window is to press ⬆/+ and Ⓜ keys to scroll the screen. For example, if the current window ID code is M02, press ⬆/+ key to enter Window M01, press the ⬆/+ button again to enter Window M00; then, press the ⬇/- key to back Window M01, and press the ⬇/- key again to enter Window M02.

Windows are separated into three types: (1) Data Type, such as M11, M12; (2) Option Type, such as M14; (3) Pure Display Type, such as M01, M00.

You can check the corresponding parameters by visiting the Data Type Windows. If you want to modify the parameters, input the digits and press Ⓜ or press Ⓜ first, input the digits then press Ⓜ again to confirm.

Example1: To enter a pipe outside diameter of 219.234, the procedure is as follows:

Press Ⓜ①① keys to enter Window M11 (the numerical value displayed currently is a previous value). Now press Ⓜ key. The symbol “>” and the flashing cursor are displayed at the left end of the second line on the Screen. Then input the parameters; or do not press the Ⓜ key, directly enter ②①⑨◉②③④Ⓜ.

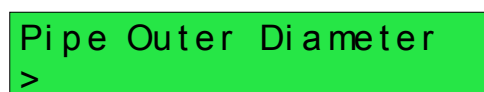

You can check the selected option by visiting Option Type Windows. If you want to modify it, you must press **ENT** first, the symbol “>” and the flashing cursor are displayed at the left of the Screen. Operator can use the **▲/+** and **▼/-** to scroll the screen and get the required value then press **ENT** to confirm; or enter the corresponding value option directly and press **ENT** to confirm.

For example, if the pipe material is not “Stainless Steel”, Press **Menu** **1** **4** to enter Window M14, press **ENT** to modify the options. Select the “1. Stainless Steel” option by pressing **▲/+** and **▼/-**, then press **ENT** to confirm the selection; It is possible to press **1** key to change the selection and wait until “1.Stainless Steel” is displayed on the second line of the screen, then press **ENT** to confirm.

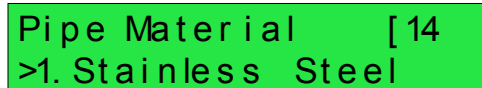

Attention



Generally, press **ENT** key first if operator wants to enter “modify” status. If the “modify” is still not possible even after pressing the **ENT** key, it means that system is locked by a password. To “Unlock” it, select “Unlock” in Window M47 and enter the original password.

1.6. Flowmeter Window Descriptions

The Flowmeter has the unique feature of windows processing for all operations.

These windows are assigned as follows:

- 00~09 Flow Totalizer Display: to display flow rate, positive total, negative total, net total, velocity, date & time, present operation and flow results today, etc.
- 10~29 Initial Parameter Setup: to enter pipe outside diameter, pipe wall thickness, fluid type, transducer type, transducer mounting method and spacing, etc.
- 30~38 Flow Units Options: to select the flow unit such as cubic meter, liter or other units, can turn totalizers on/off and reset totalizers, etc.
- 40~49 Setup options: Scaling factor, system lock (Window M47), etc.
- 50~89 Input and output setup: date and time, ESN, communication baud rate setting, etc.
- 90~94 Diagnoses: Signal strength and signal quality (Window M90), TOM/TOS*100 (Window M91), flow sound velocity (Window M92), total time and delta time (Window M93), Reynolds number and factor (Window M94), etc.
- +0~+5 Appendix: power on/off time, total working hours, on/off times and a single-accuracy function calculator.

Attention



The other windows are for hardware adjustment which reserved by the manufacturer.

2. Pipe Parameter Entry Shortcuts

For example, measuring the diameter of DN200, measuring medium is water, Pipe Material is carbon steel, No Liner, can be operated as follows:

Step1. Pipe outside diameter:

Press the **Menu** **1** **1** keys to enter Window M11, and enter the pipe outside diameter of **200**, and then press the **ENT** key to confirm.

Pipe Outer Diameter
200 mm

Step2. Pipe wall thickness

Press the **Menu** **1** **2** key to enter Window M12, and enter the pipe wall thickness of **6**, and press the **ENT** key to confirm.

Pipe Wall Thickness
6 mm

Step3. Pipe Material

Press the **Menu** **1** **4** keys to enter Window M14, press the **ENT** key, press the **▲/→** or **▼/←** key to select Pipe Material, and press the **ENT** key to confirm.

Pipe Material [14
0. Carbon Steel

Step4. Transducers type

(Transmitter support different types of transducers) Press the **Menu** **2** **3** to enter Window M23, press the **▲/→** or **▼/←** key to select transducer type, and press the **ENT** key to confirm.

Transducer Type [23
0. Standard

Step5. Transducer mounting methods

Press the **Menu** **2** **4** key to enter Window M24, press the **ENT** key, press the **▲/→** or **▼/←** key to select transducer-mounting method, and press the **ENT** key to confirm.

Transducer Mounting
0. V

Step6. Adjust Transducer spacing

Press the **Menu** **2** **5** key to enter Window M25, accurately install the transducer according to the displayed transducer mounting spacing and the selected mounting method (Refer to Installing the Transducers in this chapter).

Transducer Spacing
159.86 mm

Step7. Display measurement result

Press the **Menu** **0** **1** keys to enter Window M01 to display measurement result. (Base on the actual measurement)

Flow 0.1129 m³/h * R
Vel 1.0415 m/s

3. Measurement Site Selection

Of all flow meter types, installing an ultrasonic flow meter is the most convenient. You can start measuring simply by selecting an appropriate measuring point, inputting the pipe parameters at the measuring point to the flow meter and mounting the transducers on the pipeline.

When selecting a measurement site, it is important to select an area where the fluid flow profile is fully developed to guarantee a highly accurate measurement. Use the following guidelines when to select a proper measurement installation site:

Choose a section of pipe, which is always full of liquid, such as a vertical pipe with flow in the upward direction or a full horizontal pipe.

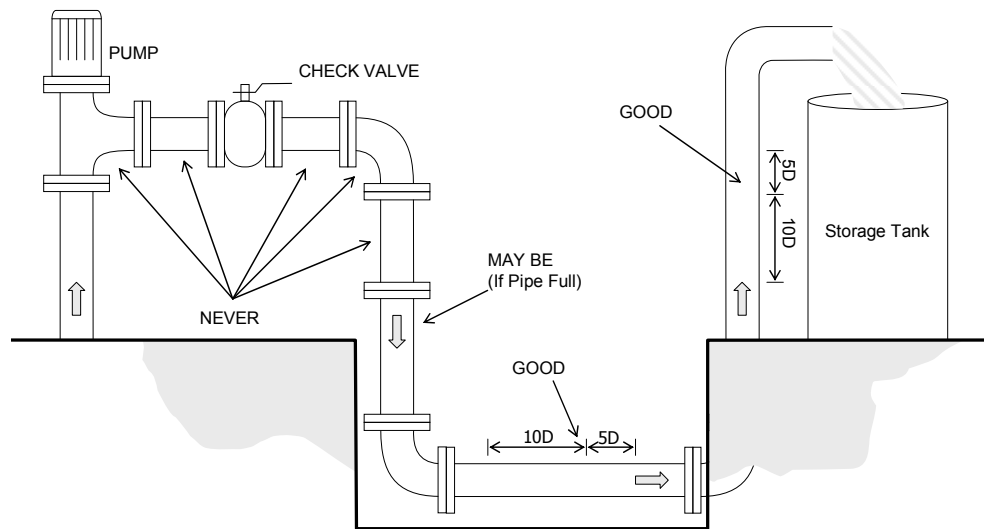

The measuring point should have a straight pipe run length equal to at least 10 pipe diameters upstream and 5 pipe diameters downstream without any throttling valves, elbow or diameter-changed device which would affect the flow field. If there is a pump, a pipe tee, adjusting valve, throttling orifice, expansion of the pipe section or any other flow disturbance producing elements above the measuring point, the upstream straight pipe section should be longer. For a horizontal pipe, transducers are usually fixed at the 9 o'clock and 3 o'clock position of the pipe.)

Avoid attaching the transducers at the 6 o'clock and 12 o'clock position to prevent signal attenuation caused by deposition at the bottom of the pipe or air bubbles and air pockets in the top of the pipeline.

Ensure that the pipe surface temperature at the measuring point is within the transducer temperature limits.

Consider the inside condition of the pipe carefully. If possible, select a section of pipe where the inside is free excessive corrosion or scaling. When cannot completely meet the condition, the corrosion or scaling should be considered as the liner to realize better measurement accuracy.

Choose a section of the pipe where the pipe material is homogeneously formed and the ultrasonic signals can be easier to transmit.

Examples acceptable measurement site selection is illustrated on the below figure.

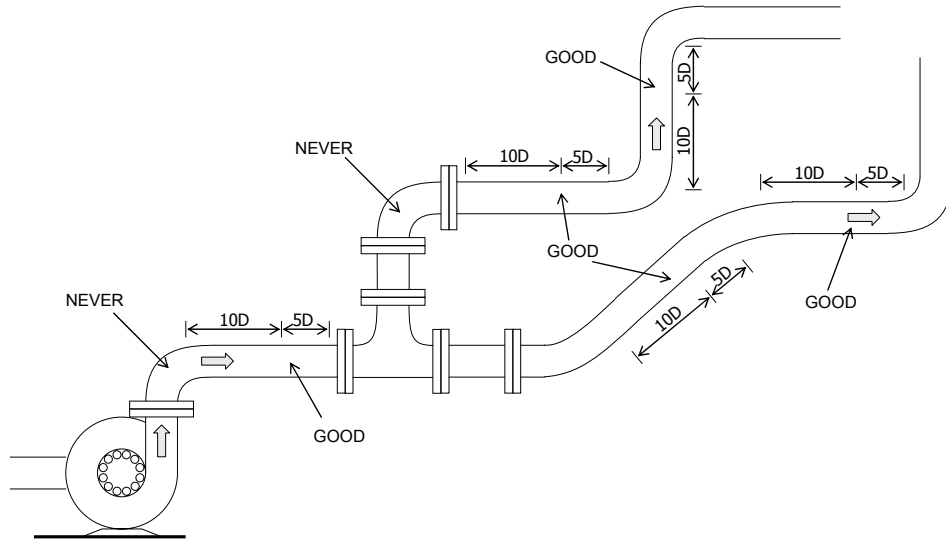

4. Transducer Installation

4.1 Installing the transducers

Before installing the transducers, clean the pipe surface where the transducers are to be mounted. Remove any rust, scale or loose paint and make a smooth surface. Choose a section of sound conducting pipe for installing the transducers. Apply a wide band of sonic coupling compound down the center of the face of each transducer as well as on the pipe surface, ensure there are no air bubbles between the transducers and the pipe wall, and then attach the transducers to the pipe with the straps provided and tighten them securely.

Note:

The two transducers should be mounted at the pipe's centerline on horizontal pipes.

Make sure that the transducer mounting direction is parallel with the flow.

During the installation, there should be no air bubbles or particles between the transducer and the pipe wall. On horizontal pipes, the transducers should be mounted in the 3 o'clock and 9 o'clock positions of the pipe section in order to avoid any air bubbles inside the top portion of the pipe. (Refer to Transducer Mounting). If the transducers cannot be mounted horizontally symmetrically due to limitation of the local installation conditions, it may be necessary to mount the transducers at a location where there is a guaranteed full pipe condition (the pipe is always full of liquid).

4.1.1 Transducer spacing

After entering the required parameters, the spacing between the ENDS of the two transducers is considered as the standard transducer spacing (Refer to Top View on transducer mounting methods). Check the data displayed in Window M25 and space the transducers accordingly.

4.1.2 Transducer Mounting Methods

Four transducer mounting methods are available. They are respectively: V method, Z method, N method and W method. The V method is primarily used on small diameter pipes (DN100~300mm, 4" ~12"). The Z method is used in applications where the V method cannot work due to poor signal or no signal detected. In addition, the Z method generally works better on larger diameter pipes (over DN300mm, 12") or cast iron pipes.

The N method is an uncommonly used method as well as is the W method. They are used on smaller diameter pipes (below DN50mm, 2").

4.1.3 V Method

The V method is considered as the standard method. It usually gives a more accurate reading and is used on pipe diameters ranging from 25mm to 400mm (1~16") approximately. Also, it is convenient to use, but still requires proper installation of the transducers, contact on the pipe at the pipe's centerline and equal spacing on either side of the centerline.

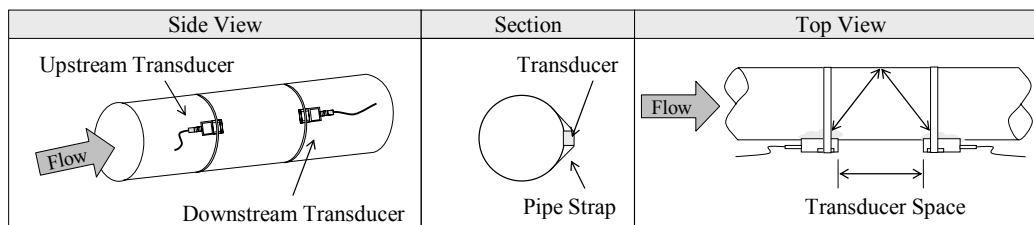

4.1.4 Z Method

The signal transmitted in a Z method installation has less attenuation than a signal transmitted with the V method when the pipes are too large, there are some suspended solid in the fluid, or the scaling and liner are too thick . This is because the Z method utilizes a directly transmitted (rather than reflected) signal which transverses the liquid only once.

The Z method is able to measure on pipe diameters ranging from 100mm to 800mm (4" ~32") approximately. Therefore, we recommend the Z method for pipe diameters over 300mm (12").

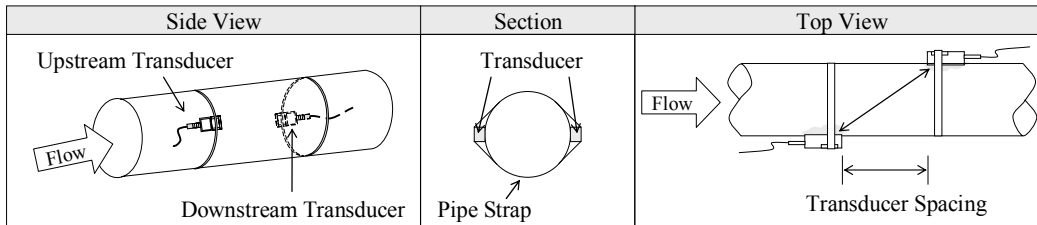

4.1.5 N Method (not commonly used)

With the N method, the sound waves traverse the fluid three times and bounce twice off the pipe walls. It is suitable for small pipe diameter measurement.

The measurement accuracy can be improved by extending the transit distance with the N method (uncommonly used).

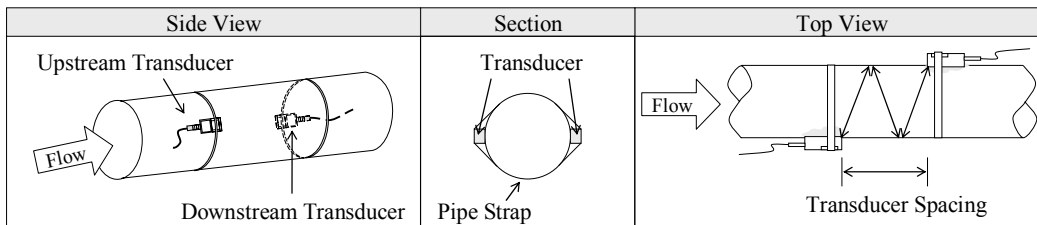

4.1.6 W Method (very rarely used)

As with the N method, the measurement accuracy can also be improved by extending the transit distance with the W method. The sound wave traverses the fluid four times and bounces three times off the pipe walls. It is suitable for very small pipe (diameters less than 50mm, 2").

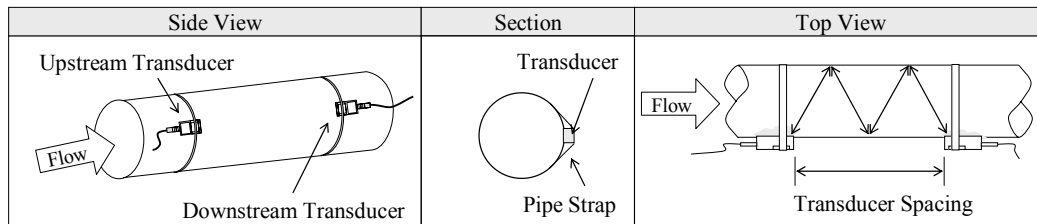

4.2 Transducer Mounting Inspection

Check to see if the transducer is installed properly and if there is an accurate and strong enough ultrasonic signal to ensure proper operation and high reliability of the transducer. It can be confirmed by checking the detected signal strength, total transit time, delta time as well as transit time ratio.

The “mounting” condition directly influences the flow value accuracy and system long-time running reliability. In

most instances, only apply a wide band of sonic coupling compound lengthwise on the face of the transducer and stick it to the outside pipe wall to get good measurement results. However, the following inspections still need to be carried out in order to ensure the high reliability of the measurement and long-term operation of the instrument.

4.2.1 Signal Strength

Signal strength (displayed in Window M90) indicates a detected strength of the signal both from upstream and downstream directions. The relevant signal strength is indicated by numbers from 00.0~99.9. 00.0 represents no signal detected while 99.9 represents maximum signal strength.

Normally, the stronger the signal strength detected, the longer the operation of the instrument reliably, as well as the more stable the measurement value obtained.

Adjust the transducer to the best position and check to ensure that enough sonic coupling compound is applied adequately during installation in order to obtain the maximum signal strength.

System normally requires signal strength over 60.0, which is detected from both upstream and downstream directions. If the signal strength detected is too low, the transducer installation position and the transducer mounting spacing should be re-adjusted and the pipe should be re-inspected. If necessary, change the mounting method to be Z method.

4.2.2 Signal Quality (Q value)

Q value is short for Signal Quality (displayed in Window M90). It indicates the level of the signal detected. Q value is indicated by numbers from 00~99. 00 represents the minimum signal detected while 99 represent the maximum.

Normally, the transducer position should be adjusted repeatedly and coupling compound application should be checked frequently until the signal quality detected is as strong as possible.

4.2.3 Total Time and Delta Time

“Total Time and Delta Time”, which displays in Window M93, indicates the condition of the installation. The measurement calculations in the Flowmeter are based upon these two parameters. Therefore, when “Delta Time” fluctuates widely, the flow and velocities fluctuate accordingly, this means that the signal quality detected is too poor. It may be the resulted of poor pipe-installation conditions, inadequate transducer installation or incorrect parameter input.

Generally, “Delta Time” fluctuation should be less than $\pm 20\%$. Only when the pipe diameter is too small or velocity is too low can the fluctuation be wider.

4.2.4 Transit Time Ratio

Transit Time Ratio indicates if the transducer mounting spacing is accurate. The normal transit time ratio should be 100 ± 3 if the installation is proper. Check it in Window M91.

Attention

If the transit time ratio is over 100 ± 3 , it is necessary to check:





- (1) If the parameters (pipe outside diameter, wall thickness, pipe material, liner, etc.) have been entered correctly,
 - (2) If the transducer mounting spacing is accordance with the display in Window M25,
 - (3) If the transducer is mounted at the pipe's centerline on the same diameter,
 - (4) If the scale is too thick or the pipe mounting is distorted in shape, etc.
-

Warnings

- (1) Pipe parameters entered must be accurate; otherwise the Flowmeter will not work properly.
 - (2) During the installation, apply enough coupling compounds in order to stick the transducers onto the pipe wall. While checking the signal strength and Q value, move the transducers slowly around the mounting site until the strongest signal and maximum Q value can be obtained. Make sure that the larger the pipe diameter, the more the transducers should be moved.
 - (3) Check to be sure the mounting spacing is accordance with the display in Window M25 and the transducer is mounted at the pipe's centerline on the same diameter.
 - (4) Pay special attention to those pipes that formed by steel rolls (pipe with seams), since such pipe is always irregular. If the signal strength is always displayed as 0.00, that means there is no signal detected. Thus, it is necessary to check that the parameters (including all the pipe parameters) have been entered accurately. Check to be sure the transducer mounting method has been selected properly, the pipe is not worn-out, and the liner is not too thick. Make sure there is indeed fluid in the pipe or the transducer is not too close to a valve or elbow, and there are not too many air bubbles in the fluid, etc. With the exception of these reasons, if there is still no signal detected, the measurement site has to be changed.
 - (5) Make sure that the Flowmeter is able to run properly with high reliability. The stronger the signal strength displayed, the higher the Q value reached. The longer the Flowmeter runs accurately, the higher the reliability of the flow rates displayed. If there is interference from ambient electromagnetic waves or the signal detected is too poor, the flow value displayed is not reliable; consequently, the capability for reliable operation is reduced.
 - (6) After the installation is complete, power on the instrument and check the result accordingly.
-

5 . Operating Instructions

5.1 System Normal Identification

Press the    keys. If the letter “*R” displays on the screen, it indicates system normal.

If the letter “E” is displayed, it indicates that the current loop output is over ranged by 100%. This refers to the settings in Window M57. Enter a larger value in Window M57, and the letter “E” will disappear. It can be ignored if no current loop output is used.

If the letter “Q” is displayed, it indicates that the frequency output is over ranged by 120%, and this refers to the settings in Window M69. Increase the input value in Window M69, and the letter “Q” will disappear. It can be ignored if no frequency output is used.

If the letter “H” is displayed, it indicates that the ultrasonic signal detected is poor. For more information, please refer to “Error Diagnoses”.

If the letter “G” is displayed, it indicates that system is adjusting the signal gain prior to the measurement. Also, it means system normal. Only when the adjustment takes too long without stopping, can system be identified as abnormal.

Letter “I” indicates no signal is being detected. Check the transducer wiring connections are correct, the transducers are installed firmly, etc.

Letter “J” indicates a hardware defect exists. Normally, such defect is temporary; it could be eliminated by system reboot (power off and restart).

Letter “F” indicates hardware defect.

For further information, please refer to “Error Diagnoses”.

5.2 Zero Set Calibration

Once zero flow occurs, a zero point may indicate on each measuring instrument, but the displayed measuring value is not equal to “0”, this value indicates “Zero”. To any measuring instrument, the smaller the “Zero” is, the better the quality is. Conversely, if the Zero is too big, that indicates the quality of the instrument is poor.

If the zero set point is not at true zero flow, a measurement difference may occur. The smaller the physical measurement capacity is, the larger the measurement difference from the zero point will exist. Only when zero point reduced to a definite degree, as compared with the physical measurement capacity, can the measuring difference from zero point be ignored.

For an ultrasonic Flowmeter, the measurement difference from zero point cannot be ignored at low flow. It is necessary to perform a static zero set calibration to improve low flow measurement accuracy.

Press Window M42 to set the Zero, press  first, and then wait the readings displayed at the lower right corner reducing to be “0”. If this is carried out with flow, the flow will be displayed as “0”, M43 can help to restore settings.

5.3 Scale Factor

Scale factor refers to the ratio between “actual value” and “reading value”. For example, when the measurand is 2.00, and it is indicated as 1.98 on the instrument, the scale factor reading is 2/1.98. This means that the best scale factor constant is 1.

However, it is difficult to keep the scale factor as “1” on the instrument especially in batch productions. The difference is called “consistency”.

During operation, there still exists possible difference in pipe parameters, etc. The “scale factor” may be necessary when used on different pipes. Thus, scale factor calibration is specially designed for calibrating the differences that result from application on different pipes. The scale factor entered must be one that results from actual calibration. The scale factor can be input in Window M45.

5.4 System Lock (Unlock)

System lock is readable but uneditable to prevent operation error due to unauthorized tampering by unauthorized personnel.

Press the **Menu** **4** **7** **ENT** keys, if displays “Unlock” on the screen, then press the **ENT** key, enter a 1~4 numerically long password, and then press the **ENT** key to confirm.

Unlock it by using the selected password only. Press **Menu** **4** **7** **ENT** , if displays “lock” on the screen press the **ENT** key and enter the correct password, then press **ENT** to confirm.

Keep the password in mind or recorded in a safe place, otherwise the instrument cannot be used.

5.5 4~20mA Current Loop Verification (Optional)

Processing a current loop output exceeding an accuracy of 0.1%, the flowmeter is programmable and configurable with multiple output modes such as flow rate or fluid velocity. Select in Window M55. For details, please refer to “Windows Display Explanations”.

In Window M56, enter a 4mA flow rate or fluid velocity value. Enter the 20mA flow rate or fluid velocity value in Window M57. For example, if the flow range in a specific pipe is 0~1000m³/h, enter 0 in Window M56 and 1000 in Window M57.

Calibrating and testing the current loop is performed in Window M58. Complete the steps as follows:

Press **Menu** **5** **8** **ENT**, move **▲/→** or **▼/←** to display “0mA”, “4mA”, “8mA”, “12mA”, “16mA”, “20mA” readings, connect an ammeter to test the current loop output and calculate the difference. Calibrate it if the difference is within tolerance. If the difference is without tolerance, refer to the “Analog Output Calibration” to calibrate the current loop.

Check the present current loop output in Window M59 as it changes along with change in flow.

5.6 Frequency Output

The Flowmeter is provided with a frequency output transmitter function. The high or low frequency output displayed indicates the high or low flow rate reading. The user can reset the frequency output as well as flow rate per his requirements.

For example: if a pipe flow range is 0~3000m³/h, the relative frequency output required is 123~1000Hz, and the configuration is as follows:

In Window M68 (low limit frequency output flow value), input 0;

In Window M69 (high limit frequency output flow value), input 3000;

In Window M67 (low limit frequency range)input 123;(high limit frequency range) input 1000.

There is no output circuit specially assigned to frequency output. It only can be transmitted through OCT, i.e. select the fifth item in Window M78 (item “5. FO”).

Typical OCT Output wiring diagram as below:

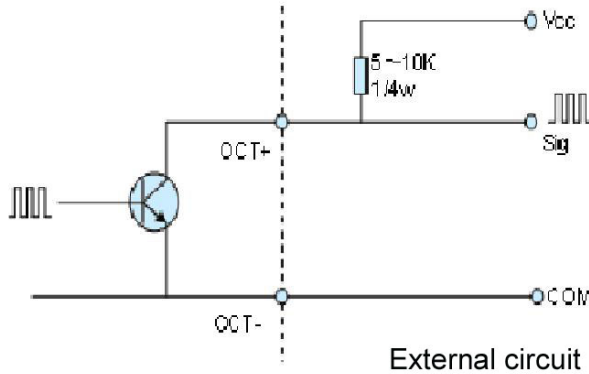

OCT Output wiring diagram

5.7 Totalizer Pulse Output

Each time the Flowmeter reaches a unit flow, it may generate a totalizer pulse output to a remote counter. The totalizer pulse output can be transmitted through OCT or Relay output. So it is necessary to configure OCT or Relay accordingly. (Please refer to Window M78, M79) For example, if it is necessary to transmit the positive totalize pulse through a Relay, and each pulse represents a flow of 0.1m³; the configuration is as follows:

1. In Window M33, select totalizer the flow unit “Cubic Meter(m³)”;
2. In Window M34, select the scale factor “2x0.1”;
3. In Window M79, select “3.Net totalizer pulse output”.

5.8 Alarm Programming

The on-off output alarm is generated through OCT or Relay output. The on-off output signal is activated under the following conditions:

1. The transmitter can not receive the ultrasonic signals;
2. Alarm #1 is out of limit;
3. Alarm #2 is out of limit.

5.9 Recover the Factory Default

Press to Window M37, press keys to recover the factory default.

5.10 4~20mA Analog Output Calibration





NOTE:

Each flowmeter has been calibrated strictly before leaving factory. It is unnecessary to carry through this step except when the current value (detected while calibrating the current loop) displayed in Window M58 is not identical with the actual output current value.

The hardware detect window must be activated prior to calibration the Analog Output. The procedure is as follows:

Press enter password “4213068”, then press to activate the detect menu. With no effect to next power on, this window will close automatically as soon as the power is turned off.

Press  to calibrate the current loop 4mA output. Use an ammeter to measure the current loop output current. At the same time, press  or  to adjust the displayed numbers. Watch the ammeter until it reads 4.00. Stop at this point, the 4mA has been calibrated.

Then, press  to calibrate the current loop 20mA output. The method is the same as 4mA calibration.

The results are automatically saved in EEPROM and won't lose when power off.

5.11 ESN

We provide the Flowmeter with a unique electronic serial number to identify each Flowmeter for the convenience of the manufacturer and customers. The ESN is able to be viewed in Window M61.



Attention

Other Operation refers to “6.2 Windows Display Explanations”.

6. Windows Display Explanations

6.1. Windows Display Codes

Flow Totalizer Display	
00	Flow Rate/Net Totalizer
01	Flow Rate/Velocity
02	Flow Rate/POS Totalizer
03	Flow Rate/NEG Totalizer
04	Date Time/Flow Rate
08	System Error Codes
09	Net Flow Today
Initial Parameter setup	
11	Pipe Outer Diameter
12	Pipe Wall Thickness
14	Pipe Material
23	Transducer Type
24	Transducer Mounting Method
25	Transducer Spacing
26	Parameters Setups
28	Holding with Poor Sig
29	Empty Pipe Setup
Flow Units Options	
30	Measurement Units
31	Flow Rate Units
32	Totalizer Units
33	Totalizer Multiplier
34	Net Totalizer
35	Pos Totalizer
36	NEG Totalizer
37	Totalizer Reset
38	Manual Totalizer
Setup Options	
40	Damping
41	Low Flow Cutoff Value
42	Set Static Zero
43	Reset Zero
44	Manual Zero Point
45	Scale Factor
46	Network identifying address code
47	System Lock
Input and output setup	
55	CL Mode Select
56	CL 4mA Output Value
57	CL 20mA Output Value

58	CL Check
59	CL Current Output
60	Date and Time
61	ESN
62	Serial Port Parameter
63	AI1 Value Range
64	AI2 Value Range
67	FO Frequency Range
68	Low FO Flow Rate
69	High FO Flow Rate
70	LCD Backlit Option
72	Working Timer
73	Alarm #1 Low Value
74	Alarm #1 High Value
75	Alarm #2 Low Value
76	Alarm #2 High Value
77	Beeper Setup
78	OCT Output Setup
79	Relay Output Setup
82	Date Totalizer
83	Automatic Correction
Calorimetry	
84	Energy Units Select
85	Temperature Select
86	Specific Heat Ratio Select
87	Energy Totalizer ON/OFF
88	Energy Multiplier
89	Reset Energy Totalizer
Diagnoses	
90	Signal Strength and Quality
91	TOM/TOS*100
92	Fluid Sound Velocity
93	Total Time and Delta
94	Reynolds Number and Factor
Appendix	
+0	Power ON/OFF time
+1	Total Working Hours
+2	Last Power Off Time
+3	Last Flow Rate
+4	ON/OFF Times
-0	Hardware Adjusting Entry

NOTE: The other menu features are retained by manufacturers and the windows in gray background are optional functions.

6.2 Display explanation

While reading this section, please compare it with the instrument in order to improve your understanding.

Menu 000

Flow Rate / Net Totalizer

Display flow rate and net totalizer.

If the net totalizer has been turned off (refer to M34), the net totalizer value displayed is the total prior to its turn off.

```
Flow 0.1154 m3/h * R
NET 0x1m3
```

Menu 001

Flow Rate / Velocity

Display flow rate and velocity.

```
Flow 0.1129 m3/h * R
Vel 1.0415 m/s
```

Menu 002

Flow Rate / Positive Totalizer

Display flow rate and positive totalizer.

Select the positive totalizer units in Window M31.

If the positive totalizer has been turned off, the positive totalizer value displayed is the total prior to its turn off.

```
Flow 0.1129 m3/h * R
POS 0x1m3
```

Menu 003

Flow Rate / Negative Totalizer

Display flow rate and negative totalizer.

Select the negative totalizer value in Window M31.

If the negative totalizer has been turned off (refer to M36), the value displayed is the total prior to turn off.

```
Flow 0.1120 m3/h * R
NEG 0x1m3
```

Menu 004

Date Time / Flow Rate

Display the current date time and flow rate.

The time setting method can be found in Window M60.

```
03-04-03 15:49:40 * R
Flow 0.1116 m3/h
```

Menu 008

System Error Codes

Display the working condition and the system error codes. More than one error code can occur at the same time.

The explanations of error codes and detailed resolution methods can be found in "Error Diagnoses".

```
* R - - - - -
System Normal
```

Menu 009

Net Flow Today

Display net total flow today.

```
Net Flow Today M09
0.458748 m3
```

Menu 1 1

Pipe Outer Diameter

Enter the pipe outside diameter or enter the pipe circumference in Window M10. The pipe outside diameter must range from 10mm to 6000mm.

Note: Enter either pipe outside diameter or pipe circumference.

Pipe Outer Diameter
50 mm

Menu 1 2

Pipe Wall Thickness

Enter the pipe wall thickness.

Pipe Wall Thickness
4 mm

Menu 1 4

Pipe Material

Enter pipe material. The following options are available (by ▲/+, ▼/- buttons or numerical keys):

0. Carbon Steel	1. Stainless Steel
2. Cast Iron	3. Ductile Iron
4. Copper	5. PVC
6. Aluminum	7. Asbestos
8. Fiber Glass-Epoxy	9. Other

The Item "9. Other" is a retained option.

Pipe Material [14
0. Carbon Steel

Menu 2 3

Transducer Type

0. Standard

1. Ty-45B

"Standard" is clamp-on type transducer,
"Ty-45B" is WS inserted type transducer(optional).

Transducer Type [23
0. Standard

Menu 2 4

Transducer Mounting

Four mounting methods are available:

0. V

1. Z use

2. N (for small pipe)

3. W (for small pipe)

Transducer Mounting
0. V

Menu 2 5

Transducer Spacing

The operator must mount the transducer according to the transducer spacing displayed (be sure that the transducer spacing must be measured precisely during installation). The system will display the data

Transducer Spacing
148.666 mm

automatically after the pipe parameter had been entered.

Menu 2 6**Initial Parameter Setups and Save**

Load and save the parameters. 18 different sets of setup conditions/groups are available to load and save by three methods (i.e.-you can load and save 18 different applications):

0. Entry to Save
1. Entry to Load
2. To Browse

Select “Entry to Save”, press **ENT**. An ID code and the original parameters are displayed in the window. Press UP or DOWN ARROW to move the ID code, then press the **ENT** key again to save the current parameter in the current ID room.

When selecting “Entry to Load”, press ENT, and the system will read and calculate the parameters automatically and display the transducer mounting spacing in Window M25.

Parameter Setups
Entry to SAVE

Menu 2 8**Holding with Poor Sig**

Select “Yes” to hold last good flow signal displayed if the Flowmeter experiences a poor signal condition. This function will allow continued data calculation without interruption.

Holding with Poor Sig
NO

Menu 2 9**Empty Pipe Setup**

This parameter is used to overcome the possible problems that usually show up when the pipe being measured is empty. Since signals can be transmitted through the pipe wall, the flow meter may still read a flow while measuring an empty pipe. To prevent this from happening, you can specify a value. When the signal quality falls below this value, the measurement stops automatically. If the flow meter is already able to stop measuring when the pipe is empty, a value in the range of 30 to 40 should also be entered in this window to ensure no measurement when the pipe is empty.

Empty Pipe Setup [29
0

Menu 3 0**Measurement Units Options**

Select the measurement unit as follows:

0. Metric
1. English

Factory default is metric.

Measurement Units In
0. Metric

Menu 3 1

Flow Rate Units Options

The following flow rate units are available:

- 0. Cubic Meters (m3)
- 1. Liters (l)
- 2. USA Gallons (GAL)
- 3. Imperial Gallons (Imp gal)
- 4. Million Gallons (mg)
- 5. Cubic Feet (cf)
- 6. USA Barrels (US bbl)
- 7. Imperial Barrels (Imp bbl)
- 8. Oil Barrels (Oil bbl)

Flow Rate Units [31]
m3/h

The following time units are available:

- /Day /Hour
- /Min /Sec

Factory default is Cubic Meters/hour

Menu 3 2

Totalizer Units Options

Select totalizer units. The available unit options are as same as those found in Window M31. The user can select units as their requirement. Factory default is Cubic Meters.

Totalizer Units [32]
Cubic Meter (m3)

Menu 3 3

Totalizer Multiplier Options

The totalizer multiplier acts as the function to increase the totalizer indicating range. Meanwhile, the totalizer multiplier can be applied to the positive totalizer, negative totalizer and net totalizer at the same time.

The following options are available:

- 0. X0.001(1E-3)
- 1. X0.01
- 2. X0.1
- 3. X1
- 4. X10
- 5. X100
- 6. X1000
- 7. X10000(1E+4)

Totalizer Multiplier
0. x0.001(1E- 3)

Factory default factor is x1

Menu 3 4

ON/OFF Net Totalizer

On/off Net Totalizer. "ON" indicates the totalizer is turned on, while "OFF" indicates it is turned off. When it is turned off, the net totalizer displays in Window M00 will not change. Factory default is "ON".

Net Totalizer [34]
ON

Menu 3 5

ON/OFF POS Totalizer

On/off POS Totalizer. "ON" indicates the Flowmeter starts to totalize the value. When it is turned off, the positive totalizer displays in Window M02 will not change. Factory default is "ON".

POS Totalizer [35]
ON

Menu 3 6

ON/OFF NEG Totalizer

On /off NEG Totalizer. "On" indicates the totalizer is turned on. When it is turned off, the negative totalizer displays in Window M03 will not change.

Factory default is "ON".

NEG Totalizer [36]
ON

Menu 3 7

Totalizer Reset

Totalizer reset; all parameters are reset. Press ENT; press ▲/+ or ▼/- arrow to select "YES" or "NO".After "YES" is selected, the following options are available:

None: No reset;

All: Reset all totalizers;

NET Totalizer Reset;

POS Totalizer Reset;

NEG Totalizer Reset.

Totalizer Reset? [37]
Selection

If the user wants to delete all the already set parameters and set back to the factory default, press ◂◃ in this window and then the flow meter will reset to be the factory default automatically.



Attention

This operation will delete the entire user's data and reset as the factory default. Please consider carefully before taking this operation.

Menu 3 8

Manual Totalizer

The manual totalizer is a separate totalizer. Press ENT to start, and press ENT to stop it. It is used for flow measurement and calculation.

Manual Totalizer [38]
Press ENT When Ready

Menu 4 0

Damping Factor

The damping factor ranges from 0~999 seconds. 0 indicates no damping; 999 indicates the maximum damping.

The damping function will stabilize the flow display.

Its principle is the same as that in a single-section RC filter. The damping factor value corresponds to the circuit time constant.

Usually a damping factor of 3 to 10 is recommended in applications.

Menu 4 1

Low Flow Cutoff Value

Low Flow Cutoff is used to make the system display as “0” value at lower and smaller flows to avoid any invalid totalizing. For example, if the cutoff value is set as 0.03, system will take all the measured flow values below ± 0.03 as “0”. Usually 0.03 is recommended in most applications.

Menu 4 2

Set Static State Zero

When fluid is in the static state, the displayed value is called “Zero Point”. When “Zero Point” is not at zero in the Flowmeter, the difference is going to be added into the actual flow values and measurement differences will occur in the Flowmeter.

Set zero must be carried out after the transducers are installed and the flow inside the pipe is in the absolute static state (no liquid movement in the pipe). Thus, the “Zero Point” resulting from different pipe mounting locations and parameters can be eliminated. The measuring accuracy at low flow is enhanced by doing this and flow offset is eliminated.

Press **ENT**, wait for the processing instructions at the right corner bottom to reach 0.

Performing Set zero with existing flow may cause the flow to be displayed as “0”. If so, it can be recovered via Window M43.

Menu 4 3

Reset Zero

Select “YES”; reset “Zero Point” which was set by the user.

Menu 4 4

Manual Zero Point

This method is not commonly used. It is only suitable for experienced operators to set zero under conditions when it is not preferable to use other methods. Enter the value manually to add to the measured value to obtain the actual value. For example:

$$\text{Actual measured value} = 250 \text{ m}^3/\text{H}$$

Damping [40]
10 sec

Low Flow Cutoff Val.
0.01 m/s

Set Zero [42]
Press ENT to go

Reset Zero [43]
NO

Value Deviation = -10 m3/H

Flowmeter Display = 240 m3/H

Normally, set the value as “0”.

Manual Zero Point [44
0 m3/h

Menu 4 5

Scale Factor

The scale factor is used to modify the measurement results. The user can enter a numerical value other than “1” according to the actual calibration results.

Scale Factor [45
1

Menu 4 6

Network IDN

Input system identifying code, these numbers can be selected from 0~65535 except that 13 (0DH ENTER), 10 (0AH Newline), 42 (2AH *) and 38 (26H&) are reserved. System IDN is used to identify the flowmeter to a network.

Network IDN [46
88

Menu 4 7

System Lock

Lock the instrument.

Once the system is locked, any modification to the system is prohibited, but the parameter is readable. “Unlock” using your designated password. The password is composed of 1 to 4 numbers.

System Lock [47
* * * * Unlocked * * * *

Menu 5 5

Current Loop Mode Select

CL Mode Select [55
0. 4 - 20 mA

Select the current loop mode. The following options are available:

- 0. 4-20mA Output Mode set up the 4-20mA output to be flow rate mode
- 1. 4-20mA vs. Vel set up the 4-20mA output to be flow velocity mode
- 2. 4-20mA vs. Energy set up the 4-20mA output to be energy mode

Other different current output characteristics are displayed in below figures. The user can select one of them according to his actual requirements.

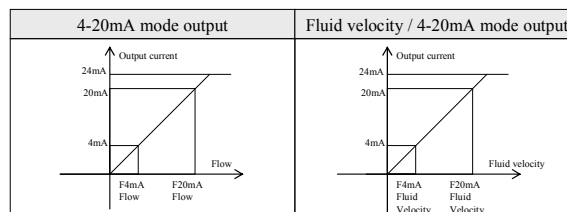

In two graphs shown above, flow F_{4mA} indicates the value that the user entered in Window M57; and flow F_{20mA} indicates the value that the user entered in Window M58. In the 4-20mA modes, F_{4mA} and F_{20mA} can be selected as a positive or negative flow value as long as the two values are not the same.

In 4-20mA flow rate mode, the output current is indicated as velocity. In 4-20mA energy mode, the output is

indicated as energy.

Menu 5 6

CL 4mA Output Value

Set the CL output value according to the flow value at 4mA. The flow unit's options are the same as those in Window M31. Once "4-20mA vs. Vel." is selected in Window M56, the unit should be set as m/s.

CL 4 mA Output Value
0 m³/h

Menu 5 7

20mA Output Value

Set the CL output value according to the flow value at 20mA. the flow unit is the same as that found in Window M31. Once "4-20mA vs. Vel." is selected in Window M57, the unit should be set as m/s.

CL 20mA Output Value
14400 m³/h

Menu 5 8

CL Check Verification

Check if the current loop has been calibrated before leaving the factory. Press **ENT** to start, press **UP** to display 0mA, 4mA, 8mA, 12mA, 16mA, 20mA, and at the same time, check with an ammeter to measure the current loop output current and calculate the differences to see if it is under the permitted tolerance. If not, refer to the "Analog Output Calibration" to calibrate.

CL Checkup [58]
Press ENT When Ready

Menu 5 9

CL Current Output

Display CL current output. The display of 10.0000mA indicates that CL current output value is 10.0000mA.

If the difference between displaying value and CL output value is too large, the current loop then needs to be re-calibrated accordingly.

CL Current Output [59]
15.661 mA

Menu 6 0

Date and Time Settings

Date and time modifications are made in this window. The format for setting time setting is 24 hours. Press **ENT**, wait until ">" appears, the modification can be made.

YY- MM- DD HH:MM:SS
03- 04- 04 10:05:04

Menu 6 1

ESN

Display electronic serial number (ESN) of the instrument. This ESN is the only one assigned to each Flowmeter ready to leave the factory. The factory uses it for files setup and the user uses it for management.

Ultrasonic Flowmeter
S/N=05071188

Menu 6 2

Serial Port Settings

This window is used for serial port setting. Serial port is used to communicate with other instruments. The serial port parameters setting of the instrument that applies the serial port connection must be consistent. The first selected data indicates baud rate, 9600, 19200, 38400, 56000, 57600, 115200 are available.

The second option indicates parity bit, None (No verification).

Data length fixed to 8;

Stop bit length for a fixed length.

The factory default serial port parameter is “9600, None”

RS- 232 Setup [62
9600, None

Menu 6 3

AI1 Analog Input Value Range

This window is for entering Analog Input 4mA and 20mA for temperature or pressure value.

AI 1 Value Range [63
10 - 100

Menu 6 4

AI2 Analog Input Value Range

This window is for entering Analog Input 4mA and 20mA for temperature or pressure value.

AI 2 Value Range [64
10 - 100

Menu 6 7

Set FO Frequency Range

Set up high FO frequency range. It must be higher than the low FO frequency. Ranges from 1-9999Hz. Factory default is 1~1001 Hz.

Note: The frequency output is transmitted through OCT Serial Port; therefore the OCT must be set to the frequency output mode.

FO Frequency Range
1 - 5000

Menu 6 8

Low FO Flow Rate

Set up low FO flow rate, i.e. the corresponding flow value when output signal frequency is at the lowest FO frequency. For example, when the low FO frequency is 1000Hz, low FO flow rate is 100m3/h then when the frequency output is 1000Hz, the low flow at this moment measured by the Flowmeter is 100m3/h.

Low FO Flow Rate [68
0 m3/h

Menu 6 9

High FO Flow Rate

Enter the high FO flow rate, i.e. the corresponding flow value when frequency output signal is at highest FO frequency. For example, when the low FO frequency is 3000Hz, low FO flow rate is 1000m3/h then when the frequency output is 3000Hz, the low flow at this moment measured by the Flowmeter is 1000m3/h.

High FO Flow Rate [69
26550 m3/h

Menu 7 0

LCD Backlit Option

Select LCD backlit controls.
0.Always OFF, 1.Always ON, 2.Lighting For nn sec
Keep the backlight off can save about 30mA power.

LCD Backlit Option
0. Always ON

Menu 7 2

Working Timer

Display the totalized working hours of the Flowmeter since last reset. It is displayed by HH:MM:SS. If it is necessary to reset it, press ENT, and select "YES".

Working Timer [72
000000 11:16:38

Menu 7 3

Alarm #1 Low Value

Enter the low alarm value. Relevant alarm is turned on in Windows M78 and M79; any of the measured flow, which is lower than the low value, will activate the alarm in the OCT hardware or Relay output signal.

Alarm #1 Low Value
0 m3/h

Menu 7 4

Alarm #1 High Value

Enter the high alarm value. Relevant alarm is turned on in Windows M78 and M79; any of the measured flow, which is higher than the high value, will activate the alarm in the OCT hardware or Relay output signal.

Alarm #1 High Value
14400 m3/h

Menu 7 5

Alarm #2 Low Value

Enter the low alarm value. Relevant alarm is turned on in Windows M78 and M79; any of the measured flow, which is lower than the low value, will activate the alarm in the OCT hardware or Relay output signal.

Alarm #2 Low Value
0 m3/h

Menu 7 6

Alarm #2 High Value

Enter the high alarm value. Relevant alarm is turned on in Windows M78 and M79; any of the measured

Alarm #2 High Value
14400 m3/h

flow, which is higher than the high value, will activate the alarm in the OCT hardware or Relay output signal.

Menu **7** **7**

Beeper Setup

Set up the beeper on-off state.

- 0. ON Beeper ON
- 1. OFF Beeper OFF

BEEPER Setup [77
0. ON

Menu **7** **8**

OCT Output Setup

Set up the output trigger event sources of the OCT hardware output components.

The following signal options are available:

1. No Signal	2. Alarm #1
3. Alarm #2	4. NET Int Pulse
5. Energy Pulse	6. FO

OCT Output Setup [78
16. Fluid changed

Menu **7** **9**

Relay Output Setup

Set up the output trigger event sources of the OCT hardware output components. RELAY is single-tool for controlling the external device.

The following signal options are available:

0. No Signal	1. Alarm #1
2. Alarm #2	3. NET Int Pulse

RELAY Output Setup
0. Not Ready (NO * R)

Menu **8** **2**

Date Totalizer

In this window, it is possible to review the historical flow data totalizer for any day of the last 64 days, any month of the last 64 months and any year of the last 5 years.

Press **ENT**, use the **▲/+** or **▼/-** to review totalizer in days, months and years. “0” for day, “1” for month, “2” for year.

Use the **▲/+** or **▼/-** to review the totalizer in some day, some month, some year.

Date Totalizer [82
0. Day

00 03- 04- 05 G- H- I
- 0 m3

For example, to display the flow total for July 18, 2000, the display “-----” at the upper right corner of the screen indicates that it was working properly

the whole day. On the contrary, if “G” is displayed, it indicates that the instrument gain was adjusted at least once. Probably it was offline once on that day. If “H” is displayed, it indicates that poor signal was detected at least once. Also, it indicates that the operation was interrupted or problems occurred in the installation. For more information please refer to “Error Code and Resolutions”.

00 03-04-05 - - - - -
>4356.78 m3

Menu 8 3

Automatic Flow Correction

With the function of automatic flow correction, the flow lost in an offline session can be estimated and automatically adjusted. The estimate is based on the average value, which is obtained from flow rate before going offline and flow measured after going online the next time, multiplied times the time period that the meter was offline. Select “ON” to use this function and “OFF” to cancel this function.

Automatic Correction
YES

Menu 8 4

Energy Unit Select

Select Energy Units, the factory default unit is GJ.

The following options are available:

- 0. Kilocalorie (Kc)
- 1. MBtu
- 2. KJ
- 3. Btu

Energy Units Select
0. Giga Joule (GJ)

Menu 8 5

Temperature Select

Select temperature signal source of energy calculation

- 0. Input from AI1, AI2
- 1. Fixed Difference in temperature

Temperature Select
0. From AI 1,AI 2

Menu 8 6

Specific Heat Select

Select the following 2 kinds of specific heat value:

- 0. Standard Specific Heat CJ-128
- 1. Fixed Specific Heat

Generally specific heat water is 0.0041868GJ/M3

Specific Heat Select
0. Standard

Menu 8 7

Energy Totalizer Switch

Select “ON” represents to open Energy Totalizer.

Energy Totalizer
ON

Select “OFF” represents to close Energy Totalizer.

Menu 8 8

Energy Multiplier

Select Energy Multiplier range: 10^{-4} ~ 10^6 (E-4~E6)

Energy Multiplier [88
4. x1 (E0)

Menu 8 9

Reset Energy Totalizer

Select “YES” to reset Energy Totalizer value.

Reset Energy Total
NO

Menu 9 0

Signal Strength and Signal Quality

Display the measured signal strength and signal quality Q value upstream and downstream.

Signal strength is indicated from 00.0 ~ 99.9. A reading of 00.0 indicates no signal detected, while 99.9 indicates maximum signal strength. Normally the signal strength should be ≥ 60.0 . Signal quality Q is indicated by 00 ~ 99. Therefore, 00 indicates the poorest signal while 99 indicates the best signal. Normally, signal quality Q value should be better than 50.

During the installation, pay attention to the signal strength and signal quality, the higher, the better. The strong signal strength and high quality value can ensure the long-term stability and the high accuracy of the measurement results.

Strength+Quality [90
UP:00.0 DN:00.0 Q=00

Menu 9 1

TOM/TOS*100

Display the ratio between the actual measured transmit time and the calculated transmit time according to customer's requirement. Normally the ratio should be $100 \pm 3\%$. If the difference is too large, the user should check whether the parameters are entered correctly, especially the sound velocity of the fluid and the installation of the transducers. This data is of no use before the system is ready.

TOM/TOS* 100 [91
0.0000%

Menu 9 2

Fluid Sound Velocity

Display the measured fluid sound velocity. Normally this value should be approximately equal to the entered value in Window M21. If the difference is too large, it probably results from an incorrect value entered in Window M21 or improper installation of the transducers.

Fluid Sound Velocity
1443.4 m/s

Menu 9 3

Total Time and Delta Time

Display the measured ultrasonic average time (unit: uS) and delta time of the upstream and downstream (unit: nS) time. The velocity calculation in the Flowmeter is based on the two readings. The delta time is the best indication that the instrument is running steadily. Normally the fluctuation in the ratio of the delta time should be lower than 20%. If it is not, it is necessary to check if the transducers are installed properly or if the parameters have been entered correctly.

Totl Time, Delta Time
8.9149uS, - 17 1.09nS

Menu 9 4

Reynolds Number and Factor

Display the Reynolds number that is calculated by the Flowmeter and the factor that is set currently by the Flowmeter. Normally this scaling factor is the average of the line and surface velocity factor inside the pipe.

Reynolds Number [94
0.0000 1.0000

Menu ▲/+ 0

Power ON/OFF Time

To view the power on/off time and flow rate for the last 64 update times to obtain the offline time period and the corresponding flow rate. Enter the window, press ENT and ▲/+ to display the last update before the last 64 times of on/off time and flow rate values. "ON" on right hand indicates that time power is on; "00" on the upper left corner indicates "00-07-18 12:40:12" the date time; flow rate is displayed in the lower right corner.

ON/OFF Time [+0
Press ENT When Ready

00- 07 18 12:40:12
* ON 123.65 m3/h

Menu ▲/+ 1

Total Working Hours

With this function, it is possible to view the total working hours since the Flowmeter left the factory. The figure on the right indicates that the total working hours since the Flowmeter left the factory is 1107 hours 1 minutes 41 seconds.

Total Wbr k Hours [+1
0001107:01:41

Menu ▲/+ 2

Last Power Off Time

Display the last power off time.

Last Power Of f Time
03- 04- 04 11:33:02

Menu ▲/+ 3

Last Flow Rate

Displays the last flow rate.

Last Flow Rate [+3
100.43 m3/h

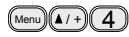

Total ON/OFF Times

Display total on/off times since the Flowmeter left the factory.

ON/OFF Times [+4
40



Analog Output Verification

Please refer to the 5.5 “4~20mA Analog Output Verification (Optional)”

Hardware Adjusting
Entry

7. Error Diagnoses

The ultrasonic Flowmeter has advanced self-diagnostics functions and displays any errors in the upper right corner of the LCD via definite codes in a date/time order. Hardware error diagnostics are usually performed upon each power on. Some errors can be detected during normal operation. Undetectable errors caused by incorrect settings and unsuitable measurement conditions can be displayed accordingly. This function helps to detect the errors and determine causes quickly; thus, problems can be solved in a timely manner according to the solutions listed in the following tables.

Errors displayed in the Flowmeter are divided into two categories:

Table 1 is for errors displayed during self-diagnostics upon power on. “* F” may be displayed on the upper left corner of the screen after entering the measuring mode. When this occurs, it is necessary to power on for self-diagnostics once again to detect and solve possible errors using the table below. If a problem still exists, please contact the factory or the factory’s local representative for assistance.

Table 2 applies when errors caused by incorrect settings and signals are detected and are announced by error codes displayed in Window M08.

7.1 Table 1. Self-diagnoses and error solutions (upon power on)

LCD Display	Cause	Solution
Rom Parity Error	System ROM illegal or error	Contact the factory
Stored Data Error	System stored data block error	Power on again or contact the factory
SCPU Fatal Error	SCPU circuit fatal error	Power on again or contact the factory
Timer Slow Error Timer Fast Error	System clock error	Contact the factory
CPU or IRQ Error	CPU or IRQ problem	Power on again
System RAM Error	System RAM questionable	Power on again or contact the factory
Time or Bat Error	System date time chip error	Power on again or contact the factory
No Display, Erratic or Abnormal Operation	Bad wiring connection	Check wiring connections
Stroke Key - No Response	Keypad locked or bad plug connection	Enter the unlock password if the keypad is locked

7.2 Table 2. Error codes and solutions (during operation)

Code	M08 Display	Cause	Solution
*R	System Normal	System normal	No errors
*J	SCPU Fatal Error	Hardware defect	Contact the factory
*I	Signal Not Detected	Signal not detected.	Attach transducer to the pipe and tighten it securely. Apply a plenty of coupling compound on transducer and pipe wall.
		Spacing is not correct between the transducers or not enough coupling compound applied to face of transducers.	Remove any rust, scale, or loose paint from the pipe surface. Clean it with a file.
		Transducers installed improperly.	Check the initial parameter settings.
		Scale is too thick.	Remove the scale or change the scaled pipe section. Normally, it is possible to change a measurement location. The instrument may run properly at a new site with less scale.
		New pipe liner.	Wait until liners solidified and saturated.
*H	Low Signal Strength	Low signal strength. Cause refers to above-mentioned reasons.	Solution refers to above-mentioned solutions.
*H	Poor Signal Quality	Poor signal quality All reasons are included in the above-mentioned causes.	Solution refers to above-mentioned solutions.
*F	Refer to Table 1.	Error in self-diagnoses during power on.	Power on again; resolve it by the method listed in Table 1. If it is still a problem, contact the factory.
		Permanent hardware error.	Contact the factory.
*G	Adjusting Gain>S1 Adjusting Gain>S2 Adjusting Gain>S3 Adjusting Gain>S4 (Display in Windows M00,M01,M02,M03)	Adjusting gain for normal measurement. Stop in S1 or S2 and only switch between S1 and S2 indicates a poor waveform or low signal strength. All reasons may be included in above-mentioned items.	
*K	Pipe Empty. Set in Window M29	No fluid in pipe or settings incorrect.	Once fluid is detected in the pipe, set 0 in Window M29.

7.3 Frequently Asked Questions and Answers

Question: New pipe, high quality material, and all installation requirements met: why still no signal detected?

Answer: Check pipe parameter settings, installation method and wiring connections. Confirm if the coupling compound is applied adequately, the pipe is full of liquid, transducer spacing agrees with the screen readings and the transducers are installed in the right direction.

Question: Old pipe with heavy scale inside, no signal or poor signal detected: how can it be resolved?

Answer: Check if the pipe is full of fluid. Try the Z method for transducer installation (If the pipe is too close to a wall, or it is necessary to install the transducers on a vertical or inclined pipe with flow upwards instead of on a horizontal pipe).

Carefully select a good pipe section and fully clean it, apply a wide band of coupling compound on each transducer face (bottom) and install the transducer properly.

Slowly and slightly move each transducer with respect to each other around the installation point until the maximum signal is detected. Be careful that the new installation location is free of scale inside the pipe and that the pipe is concentric (not distorted) so that the sound waves do not bounce outside of the proposed area.

For pipe with thick scale inside or outside, try to clean the scale off, if it is accessible from the inside. (Note: Sometimes this method might not work and sound wave transmission is not possible because of the a layer of scale between the transducers and pipe inside wall).

Question: Why is the flow rate still displayed as zero while there is fluid obviously inside the pipe and a symbol of “R” displayed on the screen?

Answer: Check to see if “Set Zero” was carried out with fluid flowing inside the pipe(Refer to Window M42). If it is confirmed, recover the factory default in Window M43.

8 Product Overview

8.1 Introduction

The SL1168 is a state-of-the-art universal transit-time Flowmeter designed using SLSI technology and low voltage broadband pulse transmission. While principally designed for clean liquid applications, the instrument is tolerant of liquids with small amounts of air bubbles or suspended solids found in most industrial environments. The flowmeter used only measuring water.

8.2 Features of SL1168

With distinctive features such as high precision, high reliability, high capability and low cost, the Flowmeter features other advantages:

1. SLSI technology designed. Less hardware components, low voltage broadband pulse transmission, low consumption power, high reliability, anti-jamming and outstanding applicability.
2. User-friendly menu designed. Parameters of pipe range, pipe material, pipe wall thickness, output signals, etc can be conveniently entered via the windows.

U.S., British and Metric measurement units are available.

3. Daily, monthly and yearly totalized flow: Totalized flow for the last 64 days and months as well as for the last 5 years are may be viewed.

Power on/off function: allows the viewing of time and flow rate as power is switched on and off 64 times. Also, the Flowmeter has manual or automatic amendment during offline sessions.

Self-contained signal output, open collector, frequency.

4. Parallel operation of positive, negative and net flow totalizes with scale factor (span) and 7 digit display, while the output of totalize pulse and frequency output are transmitted via open collector.

8.3 Theory of Operation

When the ultrasonic signal is transmitted through the flowing liquid, there will be a difference between the upstream and downstream transit time (travel time or time of flight), which is proportional to flow velocity, according to the formula below.

$$V = \frac{MD}{\sin 2\theta} \times \frac{\Delta T}{T_{up} \bullet T_{down}}$$

$$\Delta T = T_{up} - T_{down}$$

Remarks:

- V Medium Velocity
- M Ultrasonic frequency of reflection
- D Pipe Diameter
- θ The angle between the ultrasonic signal and the flow
- T_{up} Transit time in the forward direction
- T_{down} Transit time in the reverse direction

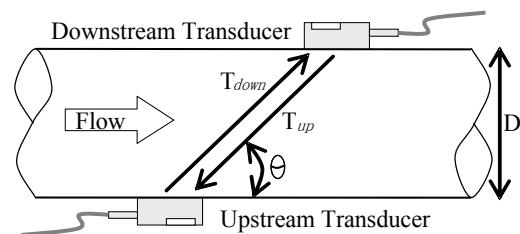

8.4 Specifications

Performance specifications	
Flow range	0~±16 ft/s (0~±5 m/s)
Accuracy	±1.0% of measured value (for 0.5~4.0 m/s or 1.5~13 ft/s)
Repeatability	0.3%
Pipe size	1 in to 32 in (25mm to 800mm)
Fluid	Water
Pipe material	Carbon steel, stainless steel, PVC, Copper, Aluminum, fiber glass, cast iron, etc.
Function specifications	
Outputs	Pulse output: 0~9999Hz, OCT, (min. and max. frequency is adjustable) Relay output: 1A/30VDC, 0.3A/125VAC Analog output(Optional): 4~20mA max load 750Ω
Input interface(Optional)	RTD 2*PT100 interface (exclude PT100 transducer) Two wires or three wires system: 0~180□ (32~352°F)
Communication interface	RS232 (Standard) RS485 (Optional) Baud rate 9600bps~115200bps
Power supply	10~24VAC or 10~36 VDC, 1A(max)
Keypad	16 (4×4) key with tactile action
Display	40 character, 2 line (20×2) lattice alphanumeric, backlit LCD
Temperature	Transmitter: -10□~50□ Transducer: 0□~60□
Humidity	Up to 99% RH, non-condensing
Physical specifications	
Transmitter	PC/ABS, IP65
Transducer	Encapsulated design, IP68
double-shielded transducer cable	Standard/maximum cable length: 30ft/1000ft (9m/305m)
Weight	Transmitter: approximately 0.7kg Transducer: approximately 0.4kg

9 Appendix 1 - Serial Interface Network Use and Communications Protocol

9.1 Overview

The flowmeter has communication protocol. It can also be connected to a RS-485.

Two basic schemes can be chosen for networking, i.e. the analog current output method only using the flowmeter or the RS232 communication method via serial port directly using the flowmeter. The former is suitable to replace dated instruments in old monitoring networks. The later is used in new monitoring network systems. It has advantages such as low hardware investment and reliable system operation.

When the serial port communication method is directly used to implement a monitoring network system, the address identification code (in window M46) of the flowmeter is used as network address code. Expanded command set with [W] is used as communication protocol. Thus analog current loop and OCT output of flowmeter can be used to control the opening of a control valve. The relay output can be used to power-on/off other equipment. The analog input of the system can be used to input signals such as pressure and temperature. The system provides an RTU function for flow measurement.

RS-232(0~15m) or RS-485(0~1000m) can be directly used for data transmission link for a short distance. Current loop, radio transmission and modem can be used in medium or long distance transmission.

When the flowmeter is used in a network environment, various operations can be performed at the host device, except for programming of the address identification code, which needs to be done at the flowmeter keyboard.

The command answer mode is used in data transmission, i.e. the host device issues commands and the flowmeter answers correspondingly.



Attention

In the communication protocol used functions, RS232 and RS485 serial communications can not be used at the same time.

9.2 Serial port definitions

Flow meter-RS232:

- TXD receive
- RXD send
- GND

PC:

- PIN 1 empty
- PIN 2 RXD receive
- PIN 3 TXD send
- PIN 4 ground
- PIN 5 ground
- PIN 6 empty
- PIN 7 empty
- PIN 8 empty
- PIN 9 empty

9.3 Direct connection via RS232 to the host device

See the below Figure Flowmeter serial port definitions.

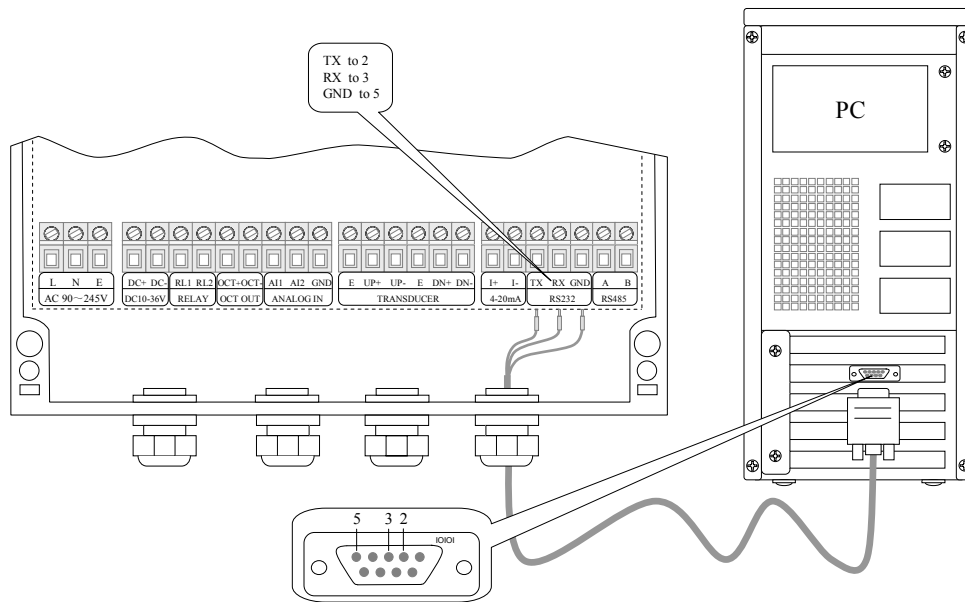

9.4 Communication protocol and the use

The communication protocol format used by the ultrasonic flowmeter is an expanded set of the Fuji FLV series flowmeter protocol. The host device requests the flowmeter to answer by sending a “command”. The baud rate of asynchronous communication (Primary station: computer system; Secondary station: ultrasonic flowmeter) is generally 9600bit/s. A single byte data format (10 bits): one start bit, one stop bit and 8 data bits. Check bit: none.

9.4.1 Basic commands

A data character string is used to express basic commands and a carriage return character is used to express the end of the command. The order applies to both RS232 and RS485. The characteristic is that the length of data is flexible. Frequently used commands are as follows:

Communication commands

Command	Description	Data format
DQD(cr)(lf)*0	Return daily instantaneous flow	±d.dddE±dd(cr) *1
DQH(cr)(lf)	Return hourly instantaneous flow	±d.dddE±dd(cr)
DQM(cr)(lf)	Return instantaneous flow per minute	±d.dddE±dd(cr)
DQS(cr)(lf)	Return instantaneous flow per second	±d.dddE±dd(cr)
DV(cr)(lf)	Return instantaneous velocity	±d.dddE±dd(cr)
DI+(cr)(lf)	Return positive accumulative flow	±dddE±d(cr) *2
DI-(cr)(lf)	Return negative accumulative flow	±dddE±d(cr)
DIN(cr)(lf)	Return net increment	±dddE±d(cr)
DIE(cr)(lf)	Return totalized energy value	±dddE±d(cr)
E(cr)(lf)	Return instantaneous energy value	±dddE±d(cr)
AI1(cr)(lf)	Return analog input value of AI1 (Temperature,Pressure,etc.)	±dddE±d(cr)
AI2(cr)(lf)	Return analog input value of AI2 (Temperature,Pressure,etc.)	±dddE±d(cr)
DID(cr)(lf)	Return identification code of instrument (address code)	ddd(cr) 5 bits in length
DL(cr)(lf)	Return signal intensity	UP:dd.d, DN:dd.d, Q=dd(cr)
DS(cr)(lf)	Return percentage of analogous output (AO)	±d.dddE±dd(cr)

DC(cr)(lf)	Return current error code	*3
DT(cr)(lf)	Current date and time	yy-mm-dd, hh:mm:ss(cr)
LCD(cr)(lf)	Return currently displayed content on LCD display	
ESN(cr)(lf)	Return electronic serial number	dddddddt(cr)(lf) *7
W	Networking command prefix of numeric string address	*8
&	Function sign of command "add"	

Note:

0. (cr)expresses carriage return. Its ASCII value is 0DH. (lf) expresses line feed. Its ASCII value is 0AH.
1. "d" expresses 0-9 number. 0 value is expressed as +0.000000E+00.
2. "d" expresses 0-9 numbers. There is no decimal point in integral part before "E".
3. The status of the machine is expressed by 1-6 letters. See the section of error code for the meaning of the characters. For example, "R" and "IH".
4. Eight "ddddddd" express electronic serial number of the machine. "t" expresses the type of the machine.
5. If there are multiple flowmeters in a data network then the basic commands cannot be used alone. The prefix N or W must be added. Otherwise, multiple flowmeters will answer simultaneously, which will causes chaos in the system.

9.4.2 Function prefix and function sign

Prefix W

Usage of prefix W: W+ numeric string address code +basic command. Value range of the numeric string is 0~65535, except 13 (0DH carriage return), 10 (0AH line feed), 42 (2AH *) and 38 (26H &). If the instantaneous velocity of No. 12345 flowmeter is to be accessed, the command W12345DV(CR) can use issued. Corresponding binary code is 57H, 31H, 32H, 33H, 34H, 3 5H, 44H, 56H and 0DH

Function sign &

Function sign & can add up to 5 basic commands (Prefix P is allowed) together to form a compound command sent to the flowmeter together. The flowmeter will answer simultaneously. For example, if No. 4321 flowmeter is requested to simultaneously return: 1] instantaneous flow, 2] instantaneous velocity, 3] positive accumulative flow, 4] thermal accumulative quantity, 5] AI1 analogous input current value, the following command is issued:

W4321PDQD&PDV&PDI+&PDIE&PBA1(CR)

Simultaneously returned data are likely as follows:

+0.000000E+00m3/d!AC(CR)

+0.000000E+00m/s!88(CR)

+1234567E+0m3 !F7(CR)

+0.000000E+0GJ!DA(CR)

+7.838879E+00mA!59(CR)

9.4.3 Modbus Protocol

The meter uses standard MODBUS protocol, which can be connected to another manufacturer's control device tied to an industrial network. There are two transmission modes: RTU and ASCII. The meter communicates with a standard MODBUS network in the RTU transmission mode. MODBUS protocol supports 03 function codes to read the data registry.

Read the information sent by the host (controller):

Slave flowmeter Address	Operating Function Code	First address of Register (Code No.)	Registry number	Error Check (2 bytes)
(0x00-0xfe)	0x03	0x00	(0x11)	CRC (Verify)

(Table 1)

The slave meter receives information frames from host successfully, and the command is validated, then the slave device sends out a return signal. The frame format is shown below:

Slave flowmeter Address	Read Operation Function Code	Data Bytes	Number of Data Bytes N	Error Check (Only for data redundancy)
(0x00-0xfe)	0x03	(0x11)		CRC (Verify)

(Table 2)

The range of slave flowmeter address (the address of flowmeter) is from 0 to 254. For example: Address = 00019 (it can be checked in the Menu 46), decimal number 19, converts Address into 1-byte hexadecimal data 0x13, and then the address of the slave flowmeter in the MODBUS protocol is: 0x13. The following slave addresses are unavailable: 13 (0DH), 10 (0AH), 42 (2AH), 38 (26H).

The first address (code) of the data registry and the number of the registry are the meter’s data transmitted via MODBUS. Refer to table 3 for its expression:

Parameter	First address register (number)	registry number	Error Check (calculate 3 bytes)
Instantaneous Flow Rate (m3/ hour)	0x00	0x11	0x5b40
Positive Totalizer	0x11	0x0e	0x88dc
Negative Totalizer	0x1f	0x0e	0xabd3
Totalizer	0x2d	0x0e	0xc824
Instantaneous Thermal Flow Rate	0x3b	0x11	0x822f
Thermal Totalizer	0x4c	0x0d	0xc05c
Analog input value 1	0x59	0x0d	0x3cda
Analog input value 2	0x66	0x0d	0x2971
Analog input value 3	0x73	0x0d	0xd5f7
Analog input value 4	0x80	0x0d	0x9365

(Table 3)

Error Check: uses the CRC verification method, using the standard CCITT polynomial method (See Table 4). Error check is formed using 16-bit with high 8-bit bytes in the beginning and low 8-bit bytes at the end. 8-bit

bytes of the first high-and low 8-bit bytes in the post

Specification	Generating Polynomial	Shorthand
CRC16-CCITT	$x^{16}+x^{12}+x^5+1$	0x1021

(Table 4)

Example:

Host sends out : 0x10 0x03 0x00 0x11 CRC code high byte CRC code low byte.

Slave flowmeter receives the information frame sent by the host, judges out the command as follows: Reads daily instantaneous flow rate from slave flowmeter with address 0x10 (decimal 16).

Slave flowmeter responds to the host : 0x10 0x03 0x11 17 bytes of data CRC code high byte CRC code low byte (CRC comes from cyclic redundancy of 17 data bytes)

Reading Parameters	Command Frame Sent by Host
Instantaneous Flow Rate (m3/hour)	100300115b40
Positive Totalizer	1003110e88dc
Negative Totalizer	10031f0eabd3
Totalizer	10032d0ec824
Instantaneous Thermal Flow Rate	10033b11822f
Thermal Totalizer	10034c0dc05c
Analog input value 1	1003590d3cda
Analog input value 2	1003660d2971
Analog input value 3	100373d5f7
Analog input value 4	1003809365

If the command sent to the slave flowmeter from the host can not be recognized, then the slave flowmeter does not return to the host.

Note: please refer to the relevant information for MODBUS protocol details.

10 Appendix2-Energy Meter—RTD Module and PT100 Wiring (Module optional)

10.1 RTD Energy Meter Function

The RTD Module's main function is to input the temperature values for the energy measurement. The SL1168 can automatically calculate the caloric content of water at different temperatures and deriving an instantaneous energy value and totalized energy value. Customers can connect PT100 sensors to the RTD module. The RTD module can convert the signals of temperature transducers to 4-20mA current signals and input them to the flow meter transmitter, or through the temperature transmitter to input 4-20mA signals directly.

10.2 Wiring

There are 2 wiring methods for the RTD module and PT100 temperature sensors — two-wire and three-wire connections.

When wiring with two wires, first jumper across A1 and B1 and A2 and B2 respectively, then connect PT100 sensors and to the RTD module according to the following diagram on the left. (Note: A1B1, A2B2 and C1C2 have the same wire color).

To connect the three wires, directly connect the PT100 sensors to the RTD module according to the following diagram on the right. (Note: A1, A2, B1, B2 are the same color, C1 and C2 are the same color).

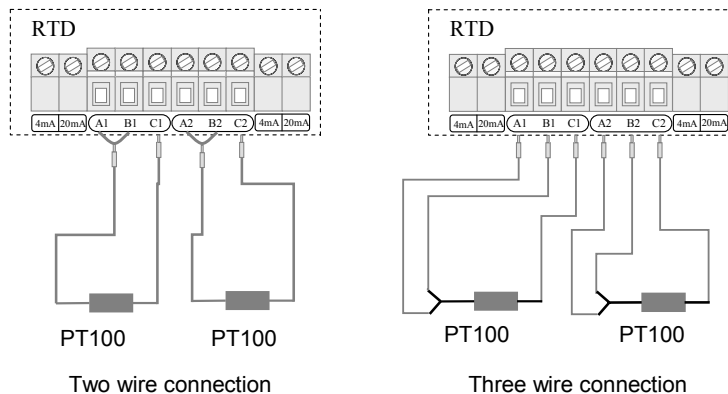

The two PT100 temperature sensors are installed on the inlet and return pipes and they will input temperature signals to the SL1168 transmitter.

10.3 Energy Measurement Methods

There are 2 formulas for flow meters to perform energy measurement functions:

Formula 1: $Q = q(V_1 - V_2)$

Q —Energy Value

q —Medium Calorific Value

V_1 —Inlet Water Volume

V_2 —Return Water Volume

Notes:

Select energy units in window M84

Differential temperature: Temperature difference of Analog Input AI1, AI2 (transmitted from 2 temperature sensors)

Specific heat (C): Enter the specific heat in window M86 (generally select the fixed specific heat of 0.0041868GJ/M3 for water.

Formula 2: $Q = m(h1 - h2)$

Q—Energy Value

m—quality of the medium(density \times transit time water volume)

h1—enthalpy value of the inlet water

h2—enthalpy value of the return water

The temperature and pressure at the inlet and return water points can be measured by temperature sensors and a transmitter, and pressure sensors and a transmitter. Then the enthalpy value at the inlet and return water points can be calculated through the enthalpy values table. The flow of the medium can be measured via the ultrasonic flow sensors and SL1188 transmitter, and the caloric value can be derived according to the above formulas and the caloric calibration index.

10.4 Temperature Range Adjustment

Temperature signals are input from the 2 PT100 temperature sensors and the values of the measurement range are entered into Windows M63 and M64.

Example: When the PT100 temperature is set to be 0°C, then the RTD module output is 4mA accordingly; when the PT100 temperature is set to be 180°C, then RTD module output is 20mA. The 4mA and 20mA corresponding to temperatures 0°C and 180°C are entered into window M63. The mADC value and the temperature value of AI1 and AI2 are displayed in Window M06.

Related energy meter windows include:

Window M05: Display transit-time energy value and totalized energy value

Window M06: Display mADC value and the corresponding temperature values of AI1, AI2 or the RTD module

Window M63: Enter the temperature values corresponding to AI1 4mA and 20mA analog inputs

Window M64: Enter the temperature values corresponding to AI2 4mA and 20mA analog inputs

Window M84: Energy units selection

Window M85: Temperature source selection

Window M86: Calorific capacity

Window M87: Energy totalizer switch

Window M88: Energy multiplier

Window M89: Reset energy totalizer

10.5 RTD Module Calibration Methods

There are two methods to calibrate the RTD module (customers can choose the proper one to calibrate according to the actual situation).

Method One: Resistance box calibration method

Note: The purpose is to calibrate the internal circuit of RTD module

Tools needed: one DC resistance box, 3 wires (each wire less than 40mm long), and an instrument screwdriver.

1. RTD module A1 and B1 will need to be jumpered, and then connect B1 to one end of the DC resistance box, and C1 to the other end of the DC resistance box.
2. Power on the SL1188 transmitter, set menu M63 and menu M64 to be "0-180" and then enter menu M06.
3. Set the resistance value of the DC resistance box to be 100.00Ω.

4. Adjust the 4mA potentiometer on the left of A1, and make sure the display of AI1 is 4.0000 (as long as the displayed value is to be 4.00, the latter 2 decimal can be omitted).
5. Set resistance value of the DC resistance box to be 168.46 Ω .
6. Adjust the 20mA potentiometer on the left of A1, and make sure the display of AI1 is 20.0000 (as long as the displayed value is to be 20.00, the latter 2 decimal can be omitted).
7. Jumper A2 and B2 the RTD module and then connect B2 to one end of the DC resistance box and C2 to the other end of the DC resistance box.
8. Power on the SL1188 transmitter, set menu M63 and menu M64 to "0-180" and then enter menu M06.
9. Set the resistance value on the DC Resistance box to be 100.00 Ω .
10. Adjust the 4mA potentiometer on the right of C2 to make the display of AI2 is 4.0000, as long as the displayed value is 4.00, the latter 2 decimal can be omitted.
11. Set the resistance value of the DC Resistance box to be 168.46 Ω .
12. Adjust the 20mA potentiometer on the right of C2 and make sure the display of AI2 reads 20.0000 (as long as the displayed value is to be 20.00, the latter 2 decimal can be omitted).

Method Two: Liquid standard temperature calibration method

Note: It is used to calibrate the internal circuit of RTD module and the PT100 temperature sensors together

1. Directly put the sensor end of a PT100 temperature sensor into a mixture of ice and water (the temperature is 0°C), and the other end connects with the RTD module (adjust the electric potentiometer to 4mA accordingly to ensure the display of M63 is 4.00).
2. After the restoring the temperature sensors back to room temperature, put them into a constant temperature oil/water bath (the temperature is 180°C.) NOTE: The customer can choose the liquid temperature according to the actual requirements. Adjust the 20mA electric potentiometer accordingly to ensure the display in M63 is 20.00.
3. The calibration method of the other PT100 temperature sensor is the same as above.