

Thermo Scientific Sarasota FD910 Sarasota FD950 Sarasota FD960

Liquid Density Meters for
General Industrial, Chemical
and Fiscal Applications

Thermo Scientific Sarasota liquid density meters accurately measure density or density related variables. These online continuous meters provide key information for process monitoring and control, quality control, product interface detection, and custody transfer applications to minimize product waste and reduce costs.



Features

- Continuous, online density monitoring
- Measurement at process conditions
- Straight through flow path
- Materials to suit applications
- Compact and lightweight, easy to install
- Hazardous area approvals
- Converter electronics to suit application



Applications

- Blending
- Product identification
- Interface detection
- Dilution measurement
- Process/quality control
- SG measurement
- Process efficiency
- Waste minimization
- Product consistency
- Volumetric to mass flow metering systems



Repeatable & Accurate

Thermo Scientific Sarasota liquid density meters fulfill demanding application requirements within the oil and gas, petrochemical, and chemical industries. These devices utilize the proven vibrating element design which is widely accepted as the most accurate method of continuous, online density measurement. In fact, our twin tube design is inherently more stable than single tube technology, and an integral, high grade PT100 temperature element within the instrument allows compensation of the density meter for temperature effect and may be used for compensation to reference conditions. Our meters detect any variation of process constituents or final product quality in near real-time to improve productivity, minimize product waste and reduce costs when compared to sampling methods.

Compact & Easy-to-Install

Compact and lightweight, the density meters tolerate significant plant vibration and can be installed directly into existing pipe work without the need for upstream flow conditioning or instrument supports. Installation is quick and simple with minimal pipeline disturbance or process downtime. The straight-through sensor offers an unobstructed flow path to ensure minimal pressure drop and higher flow rates to keep your products moving at optimal speed.

Durable & Functional

A choice of sensor materials is offered for wetted parts, including Hastelloy® C276 for improved corrosion resistance, Ni-Span C® for its low temperature coefficient for fiscal applications, and stainless steel for general industrial use. With hazardous area approvals and secondary containment on all models, these dependable instruments withstand tough industrial environments to ensure a significant return on investment.

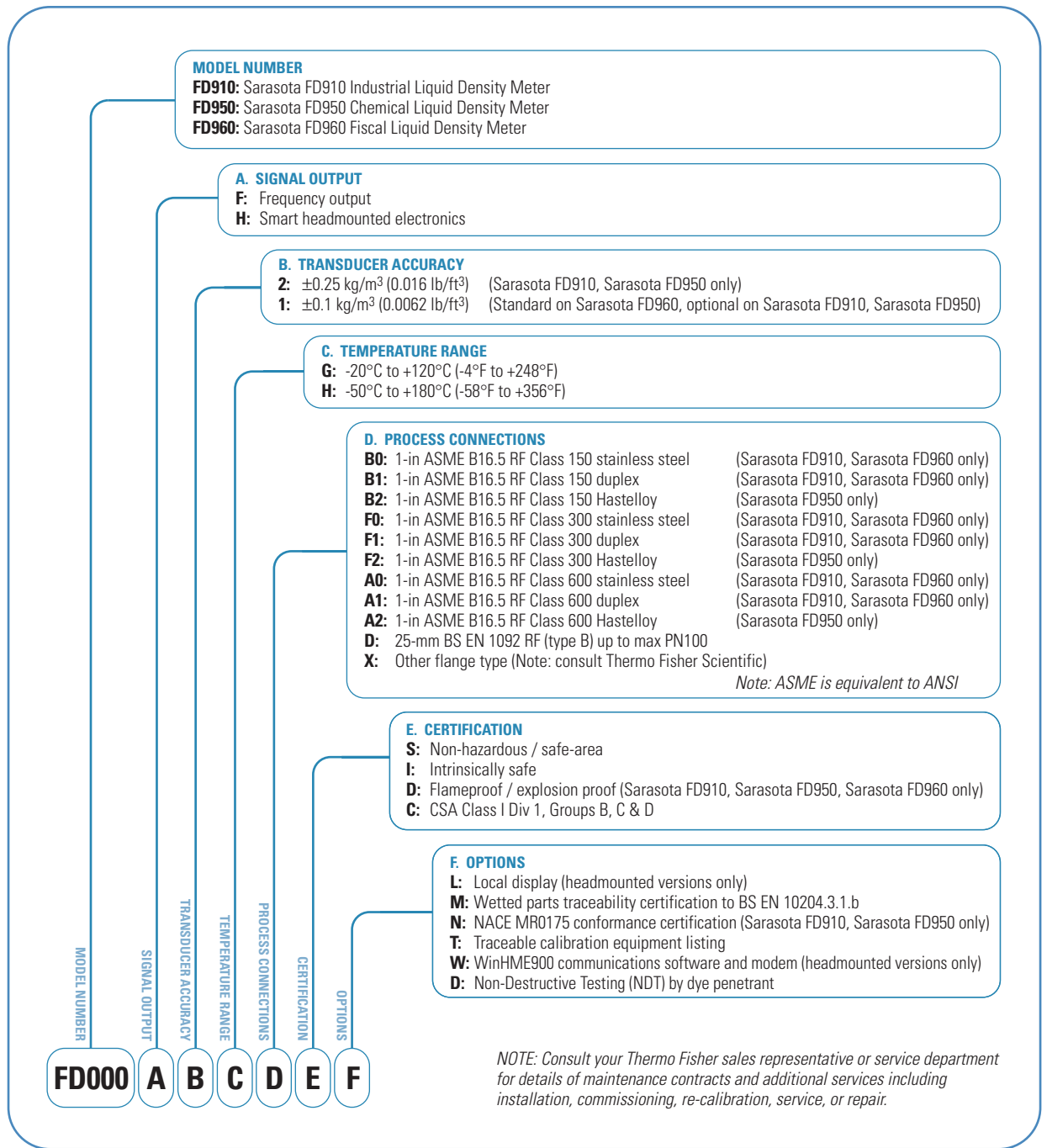

The Sarasota FD910 for Industrial Applications

The Sarasota FD910 meets the demands of general process monitoring and control applications across a vast number of industries. With its stainless steel construction, the Sarasota FD910 industrial density meter is best suited to those general process applications that do not require the specialist materials offered by the other models in the range.

The Sarasota FD950 for Chemical Applications

The wetted parts of the Sarasota FD950 are made of Hastelloy C276 making it the most corrosion resistant option of the range. It is ideal for aggressive applications in the petrochemical, chemical and pharmaceutical industries.

The Sarasota FD960 for Fiscal/Custody Transfer Applications

High-value liquid hydrocarbons must be identified and measured accurately and quickly to minimize product waste and determine custody transfer responsibilities. The superior performance of the Sarasota FD960 fiscal density meter makes it the right choice for custody transfer as well as multi-product pipeline metering and interface detection systems. The low temperature coefficient of Ni-Span C wetted parts allows the Sarasota FD960 to offer superior accuracy with minimal pressure drop. Typical applications include product blending, batch control, dilution measurement, product identification, interface detection and tanker loading.



Calibration and Service

Calibration of Thermo Scientific liquid density meters is conducted in-house on a calibration rig that is traceable to national standards. Supporting documentation is available including a traceable equipment list. For most applications, installation is straightforward, on-site calibration is generally unnecessary and the instruments are usually maintenance-free. However, our dedicated service team offers installation, commissioning, maintenance and repair service for our liquid density meters and associated electronics. On-site visits, in-house repairs and maintenance contracts can be arranged as required.

Sarasota FD910 / Sarasota FD950 / Sarasota FD960 Dimensional Diagram

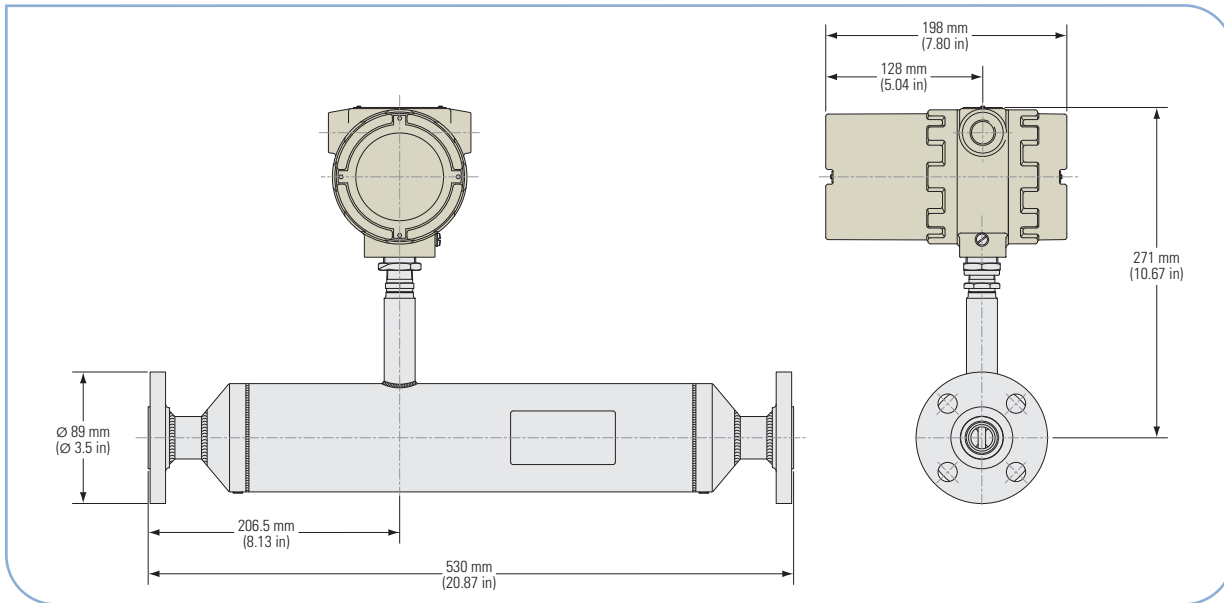

Thermo Scientific Sarasota HME900



Thermo Scientific Sarasota CM515

Density Converter Electronics

Thermo Scientific Sarasota liquid density meters can provide output variables, such as specific gravity, % concentration, °Brix, °API, °Baume, line density or referred density, when used in conjunction with a Sarasota density converter. The Thermo Scientific Sarasota HME900 field mounted density converter option provides a direct HART® compatible 4-20 mA output, whereas the Sarasota CM515 panel-mounted computer provides a local display and a variety of operator selectable outputs that feed into a plant's optimization system. Contact us today to learn how our range of products will help you reduce waste as well as improve your process and your bottom line.

Thermo Scientific Sarasota Liquid Density Meters

Functional Specifications	
Transducer Calibration Accuracy	Available to $\pm 0.1 \text{ kg/m}^3$ ($\pm 0.0062 \text{ lb/ft}^3$)
Repeatability	0.02 kg/m^3 (0.0012 lb/ft^3)
Flow Range	Vertical installation: 0 l/min to 300 l/min (0 USG/min to 79 USG/min); Horizontal installation: 5 l/min to 300 l/min (1.3 USG/min to 79 USG/min)
Operating Density Range	0 kg/m^3 to 2100 kg/m^3 (0 lb/ft^3 to 131.1 lb/ft^3)
Installation	Vertical installation (standard), horizontal installation (optional); No instrument or pipework supports required
Pressure Effect (corrected)	0.003 $\text{kg/m}^3/\text{bar}$ (0.00013 $\text{lb/ft}^3/\text{psi}$) note: correction coefficients applied
Temperature Effect (corrected)	0.005 $\text{kg/m}^3/^\circ\text{C}$ (0.0002 $\text{lb/ft}^3/^\circ\text{F}$) note: correction coefficients applied
Density Meter Dimensions	See dimensional diagrams
Shipping Dimensions	590 mm x 390 mm x 290 mm (approx 24 in x 16 in x 12 in)
Net Weight	11 kg (24 lb)
Shipping Weight	15 kg (33 lb)
Environmental Rating	IP65 (NEMA 4X)
Electrical Connections	Screw terminals; Cable entry: 2 x 3/4-in NPT
Temperature Measurement	High accuracy 1/2 DIN integral 4-wire PT100
Local Display (H option)	4 1/2-digit 7.6 mm (0.3 in) 7-segment LCD display. Resolution 0.1% or 0.01% depending on display variable.
Secondary Containment	As flange rating to Class 300 then 2.5 times maximum safety flange rating to Class 600
Factory Calibration Range	650 kg/m^3 to 1600 kg/m^3 (40.58 lb/ft^3 to 99.98 lb/ft^3)
Ambient Temperature Range	-20°C to +60°C (-4°F to +140°F) ambient
Process Temperature Range	Sarasota FD910 / FD950 / FD960: -50°C to +180°C (-58°F to +356°F)
Output	F option (frequency output): Frequency related to density on 2-wire current modulated loop 6 mA to 18 mA; 4-wire PT100 H option (headmounted electronics): Analog 4-20 mA related to density or density derived variable; HART protocol
Power Supply	F option (frequency output): 13-28 VDC 10 mA average (peak 18 mA) H option (headmounted electronics): 2 x 13-28 VDC 25 mA; 4-20 mA current pressure input available
Maximum Operating Pressure	Sarasota FD910 / FD950 / FD960: as flange rating
Material Specifications	
Sensor	Sarasota FD910 stainless steel (316L / 1.4404); Sarasota FD950: Hastelloy C276; Sarasota FD960: Ni-Span C
Other Wetted Parts	Sarasota FD910 (Class 150, 300) / FD960: 316L stainless steel (316L / 1.4404) Sarasota FD910 (Class 600) / FD950: Hastelloy C276
Case	Stainless steel (316L / 1.4404)
Electronics Housing	Copper free aluminum grey epoxy finish; Plate glass window for local display option
Process Connections	
1-in ASME B16.5 RF (raised face)	Sarasota FD910 / FD960: stainless steel (316L / 1.4404) – Class 150, 300 or 600 Sarasota FD910 / FD960: duplex (A 182 Gr.F51) – Class 150, 300 or 600 Sarasota FD950 only: Hastelloy C276 – Class 150, 300 or 600
25-mm BSEN1092 RF (raised face - type B)	Sarasota FD910 / FD950 / FD960: Up to maximum PN100
Other Flange Types	Consult Thermo Fisher
Compliance/Certification	
Quality Assurance	ISO 9001:2000
CE mark	Compliant
Electromagnetic Compatibility	Compliant (EN 61326:1997)
Pressure Equipment Directive (97/23/EC)	Sarasota FD910 / FD950 / FD960: category III
Low Voltage Directive	Compliant
Safe Area Use	As standard
BS EN ISO 15156 / NACE MR0175	
Conformance	Available on Sarasota FD910 and Sarasota FD950 only
ATEX Conformance: Intrinsically Safe (94/9/EC)	F option (frequency output): Ex II 1 G EEx ia IIC T6 (-20°C \leq Ta \leq +60°C) H option (headmounted electronics): Ex II 1 G EEx ia IIC T4 (-20°C \leq Ta \leq +60°C)
ATEX Conformance: Flameproof (94/9/EC)	Sarasota FD910 / FD950 / FD960 only: Ex II 2 G EEx d IIC T4 (Tamb = -20°C to +60°C) or T3 (Tamb = -20°C to +60°C) Temperature classification of T4 or T3 for use with maximum process fluid temperature of +115°C or +180°C respectively
Canadian Standards Association (CSA)	Sarasota FD910 / FD950 / FD960 only: Explosion-proof Class 1, Groups B, C and D
Calibration Certification	Calibration traceable to national standards. Calibration certificates supplied as standard. Optional traceable calibration equipment listing available
Material Traceability	Wetted parts traceability to BS EN 10204.3.1.b; Certification available

©2008 Thermo Fisher Scientific Inc. All rights reserved. HART is a registered trademark of the HART Communication Foundation. Tri-Clamp is a registered trademark of Tri-Clover, Inc. Hastelloy is a registered trademark of Haynes International, Inc. Ni-Span C is a registered trademark of the Special Metals Corporation. All other trademarks are the property of Thermo Fisher Scientific Inc. and its subsidiaries. Results may vary under different operating conditions. Specifications, terms and pricing are subject to change. Not all products are available in all countries. Please consult your local sales representatives for details. Literature Code PI.2024.1108

Room 1010 - 1019	+86 (10) 5850-3588
Ping'an Mansion No. 23 Jinrong Street	+86 (10) 6621-0847 fax
Xicheng Dist, Beijing 100032 CHINA	
A-101, ICC Trade Tower, Senapati Bapat Road	+91 (20) 6626 7000
Pune 411016 Maharashtra, INDIA	+91 (20) 6626 7001 fax
Ion Path, Road Three, Winsford	+44 (0) 1606 548700
Cheshire CW7 3GA UNITED KINGDOM	+44 (0) 1606 548711 fax
1410 Gillingham Lane	+1 (800) 437-7979
Sugar Land, TX 77478 USA	+1 (713) 272-0404
	+1 (713) 272-4573 fax

www.thermo.com

Thermo
SCIENTIFIC