

Application BC04

Dual Stage Batch Controller

for Mass Analog Flowmeters

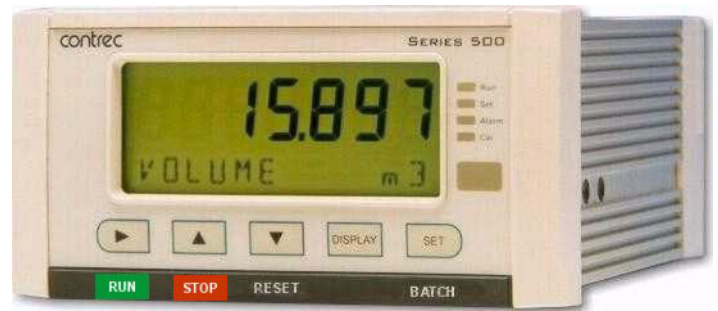

Features

- Tailored for mass analog flow input
- Single or Dual stage control
- Quick access to common batch quantities
- No-flow, leakage and overflow error detection
- Remote RUN/STOP/RESET
- Allows for non-linear correction
- Storage of 100 transactions with time and date stamp
- Selection of second language and user tags
- Infra-red communications port on front panel
- Pulse width and scaling of pulse output
- 4-20mA retransmission
- Selectable protocols on serial ports including Modbus RTU and Printer output
- Front panel adjustment of 8-24V DC output voltage
- Backlit display
- LCD backup



Overview

The 505 BC04 application is a dual stage batch controller for reliable measurement of preset quantities using a mass analog input. Used as a single or dual stage controller it is suitable for fast batch applications.

It provides the operator with clear local readout and can be controlled via communications in more automated systems. There is quick access to commonly used preset values directly from the front panel if access has been authorized. Automatic overrun compensation caters for system delays such as valve closure for precise volumes.

The analog input can be scaled as well as having filtering, non-linear correction and cutoff points applied to the signal.

Calculations

To derive the flow rate, the analog input is normalised to a value (A) between 0 and 1.

$$massflow = (M_{fmax} - M_{fmin})A + M_{fmin}$$

$$mass = \int (massflow \cdot \Delta t)$$

Automatic overrun compensation calculates the new valve closure point to ensure correct delivery by averaging the overrun amount from the last three complete batches.

The overrun compensation value is valid for a new preset value provided the stored overrun is less than 20% of the new preset.

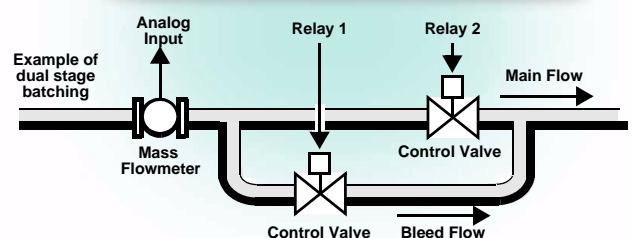

Displayed Information

The front panel display shows the current values of the input variables and the results of the calculations. A list of the variables for this application and their type (total or rate) is shown at the end of this document.

The instrument can be supplied with a real-time clock for storage of up to 100 transactions with time and date stamps.

Communications

There are three communication ports available as follows:

- RS-232 port (standard)
- RS-485 port (standard)
- Infra-red port (on front panel - display panel option)

The ports are available for remote data reading, printouts and for initial application loading of the instrument.

Retransmission & Control Outputs

The instrument can retransmit any main-menu variable. The digital outputs can retransmit totals as pulses or operate as logic levels for control or error outputs. If the instrument has the advanced option, it outputs rates as a 4-20mA signal.

Relay Outputs

The relay outputs 1 and 2 are used to control the flow of product for each delivery. These contacts are normally open and can be used to drive external relays, valves, pump circuits etc.

Software Configuration

The instrument can be further tailored to suit specific application needs including units of measurement, custom tags, second language or access levels. A distributor can configure these requirements before delivery.

Instrument parameters including units of measurement can be programmed in the field, according to the user-access levels assigned to parameters by the distributor.

Dimension Drawings

Part Number

505-XXXXXX-BC04
see **Product Codes** to select required features

Default Application software:
505-BC04-000000

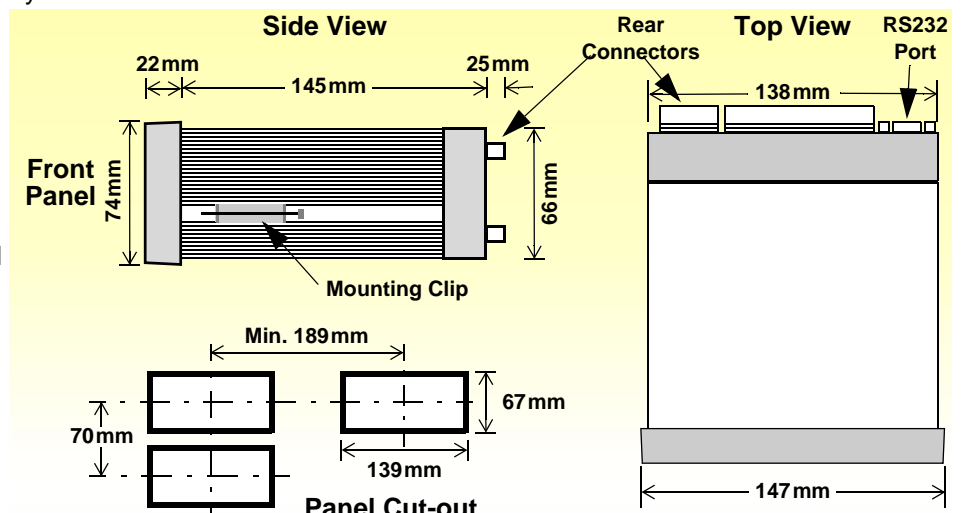

All set-up parameters, totals and logged data are stored in non-volatile memory with at least 30 years retention.

Terminal Designations

Terminal Label	Designation	Comment	
1	+	RS485 (+)	
2	-	RS485 (-)	
3	G	Comms ground	
4	Tx	RS232 data out	
5	Rx	RS232 data in	
6	C	CTS (Clear to send)	
7	Io	4-20mA output	Advanced option
8	SG	Signal Ground 0V	
9	Li	Logic input	Remote run
10	1+	Open collector o/p 1	Digital outputs
11	2+	Open collector o/p 2	
12	li	4-20mA input	Mass flow
13	SG	Signal Ground 0V	
14	Fi	Signal input	Remote stop/reset
15	Vo	8-24 volts DC output	70mA power limited
16	G	DC Ground	DC power in 12-28V
17	Vi	DC power input	
18	SH	Shield terminal	
19	R1	Relay 1	Single stage
20	RC	Relay Common	Dual stage
21	R2	Relay 2	
E	E	Mains ground	AC power in 95-135V or 190-260V
N	N	Mains neutral	
A	A	Mains active	
RS232 port		9-pin serial port	Extra option

Specifications

General

Operating Environment

Temperature	0°C to +60°C (conformal coating) +5°C to +40°C (no coating)
Humidity	0 to 95% non condensing (conformal coating) 5% to 85% non condensing (no coating)
Power Supply	95...135 V AC or 190...260 V AC or 12...28 V DC
Consumption	Typically 6W
Protection	Sealed to IP65 (Nema 4X) when panel mounted
Dimensions	147mm (5.8") width 74mm (2.9") height 167mm (6.6") depth

Display

Type	LCD with 7-digit numeric display and 11-character alphanumeric display (backlit option)
Digits	15.5mm (0.6") high
Characters	6mm (0.24") high
LCD Backup	Last data visible for 15min after power down (optional)
Update Rate	0.3 second

Non-volatile Memory

Retention	> 30 years
Data Stored	Setup, Totals and Logs

Approvals

Interference	CE compliance
Enclosure	ATEX, FM, CSA and SAA approved enclosures available for hazardous areas

Real Time Clock (Optional)

Battery Type	3 volts Lithium button cell (CR2032)
Battery Life	5 years (typical)

Inputs

4-20mA Input

Overcurrent	100mA absolute maximum rating
Impedance	250 ohms (to common signal ground)
Accuracy	0.1% typical full scale (20°C) 0.2% (full temperature range)
Non-linearity	Up to 20 correction points (flow inputs)

Remote Logic Inputs

Signal Type	Voltage free contact, open collector
--------------------	--------------------------------------

Outputs

Relay Output

No. of Outputs	2 relays
Voltage	250 volts AC, 30 volts DC maximum
Current	3A maximum

Communication Ports

Ports	RS-232 port RS-485 port Infra-red port (optional)
Baud Rate	2400 to 19200 baud
Parity	Odd, even or none
Stop Bits	1 or 2
Protocols	ASCII, Modbus RTU, Printer (RS232)

Transducer Supply

Voltage	8 to 24 volts DC, programmable
Current	70mA @ 24V, 120mA @ 12V maximum
Protection	Power limited output

Pulse/Digital Output

Signal Type	Open collector, non-isolated
Switching	200mA, 30 volts DC maximum
Saturation	0.8 volts maximum
Pulse Width	Programmable: 10, 20, 50, 100, 200 or 500ms

4-20mA Output (Optional)

Supply	24 volts DC internal, non-isolated
Resolution	0.05% full scale
Accuracy	0.05% full scale (20°C) 0.1% (full temperature range, typical)

Important: Specifications are subject to change without notice.

Ordering Information

Customer:

Purchase Order Ref:

If custom settings are required prior to delivery, please specify the preferences in the table below. Include this form with the purchase order and specify "Custom Selection Attached". (Units of measurement can be changed in field if required).

Product Codes

Model	Supplementary Code						Description
505	- BC04						
Enclosure	1						Panel mount enclosure
	2						Field mount enclosure (not yet available)
	3/5						Explosion proof Ex410 with metric glands (5 specifies heater version)
	4/6						Explosion proof Ex410 with NPT glands (6 specifies heater version)
Output Options	0						Basic - RS232 and RS485 serial ports, 2 relays, 2 pulse outputs, rear key input
	1						Advanced - also includes 4-20mA o/p and Real-time clock for printer output and logging (100 logs)
Extra Options	2						9 way DB connector for RS232 serial port
Power Supply	E						For 220/240 VAC
	A						For 110/120 VAC
	D						For DC power only 12-28 VDC
Display Panel Options	S						Standard (no backlight, LCD backup or Infra-Red comms port)
	F						Fully optioned (with backlight, LCD backup and Infra-Red comms port)
PCB Protection	C						Conformal coating - required for maximum environmental operating range. Recommended to avoid damage from moisture and corrosion.
	N						None - suitable for IEC standard 654-1 Climatic Conditions up to Class B2 (Heated and/or cooled enclosed locations)
Application Pack Number	BC04						Defines the application software to be loaded into the instrument

Example full product part number is 505.112EFC-BC04 (This is the number used for placing orders).

Main Menu Variables

Main Menu Variables	Default Units	Preferred Units	Variable Type
Mass	kg		Total
Mass Flowrate	kg/min		Rate

Please specify the preferred units of measurement.



500 Series in Ex410 Enclosure

www.contrec.com.au

Contrec Pty Ltd

22 Hall Street Hawthorn East
 Victoria 3123 AUSTRALIA
 Tel: +61 3 9804 4200 Fax: +61 3 9822 8329
 Email: sales@contrec.com.au

Contrec Europe Limited

PO Box 436 Sowerby Bridge,
 West Yorkshire HX6 3YA, UK
 Tel: +44 1422 829 940 Fax +44 1422 829 941
 Email: sales@contrec.co.uk

Contrec - USA, LLC

916 Belcher Drive, Pelham AL 35124 USA
 Tel: (205) 685 3000 Fax: (205) 685 3001
 Email: contrec@contrec-usa.com

A Delft Instruments company