

Model 505 Flow Computer

Operation Manual

Application BC02

Dual Stage Batch Controller
for
Volumetric Analog Flowmeters



contrec

29 December 2005

Model 505 Flow Computer - Operation Manual

© Contrec Pty Ltd 2005

The instructions given herein cover the general description, installation, operation and maintenance of the subject equipment. Contrec Pty. Ltd. reserves the right, without prior notice, to make engineering refinements that may not be reflected in this manual.

Should any questions arise which cannot be answered specifically by this manual, they should be directed to Contrec Pty Ltd for further detailed information and technical assistance.

Contrec Pty. Ltd. will not accept any liability for either direct or consequential damages resulting from the use or misapplication of the contents of this manual.

Part of the software embedded in this product is eCos - Embedded Configurable Operating System, a trademark of Red Hat. Portions created by Red Hat are Copyright © 1998, 1999, 2000 Red Hat, Inc. (<http://www.redhat.com>). All rights reserved

The software in this product was in part provided by Red Hat and any express or implied warranties, including, but not limited to, the implied warranties of merchantability and fitness for a particular purpose are disclaimed. In no event shall the author be liable for any direct, indirect, incidental, special, exemplary, or consequential damages (including, but not limited to, procurement of substitute goods or services; loss of use, data, or profits; or business interruption) however caused and on any theory of liability, whether in contract, strict liability, or tort (including negligence or otherwise) arising in any way out of the use of this software, even if advised of the possibility of such damage.

Contrec Pty Ltd

22 Hall Street Hawthorn East, Melbourne 3123 AUSTRALIA
Tel: +61 3 9804 4200 Fax: +61 3 9822 8329
Email: sales@contrec.com.au

Contrec - USA, LLC

916 Belcher Drive Pelham AL 35124 USA
Tel: (205) 685 3000 Fax: (205) 685 3001
Email: contrec@contrec-usa.com

Contrec Europe Limited

PO Box 436 Sowerby Bridge, West Yorkshire HX6 3YA, UK
Tel: +44 1422 829 940 Fax: +44 1422 829 941
Email: sales@contrec.co.uk

Website: www.contrec.com.au

Publication No: 505-BC02-OM - 29 December 2005



Safety Notice

The information in this safety notice is for the prevention of injury to personnel and damage to the instrument.

The manufacturer assumes no liability for injury or damage caused by misuse of the instrument or for modifications made to the instrument.

Qualified Personnel

The instrument must be installed, operated and serviced by persons who have been properly trained and authorised. Personnel must read and understand this manual prior to installation and operation of the instrument.

Static Hazard

The 500 series flow computer uses high speed CMOS circuitry which is sensitive to static damage. The user should observe accepted safety practices for handling electronic devices, especially during servicing. Once the unit is installed, grounded and interconnected, the chances of static damage are greatly reduced.

Voltage Hazard

Before connecting power to the instrument, ensure that the supply voltage for the AC or DC input is suitable. The AC voltage rating is as stated on the serial number plate. Personnel should take all due care to avoid electric shock.

Welding Hazard

Do not perform electric welding in close proximity to the instrument or its interconnecting cables. If welding in these areas must be performed, disconnect all cables from the instrument. Failure to do so may result in damage to the unit.

Moisture Hazard

To avoid electrical faults and corrosion of the instrument, do not allow moisture to remain in contact with the instrument.

Contents

1 Introduction

| | |
|----------------------------------|---|
| Features | 1 |
| Overview | 1 |
| Calculations | 2 |
| Analog Input Scaling | 2 |
| Displayed Information | 2 |
| Main Menu Variables | 3 |
| Communications | 3 |
| Retransmission & Control Outputs | 3 |
| Relay Outputs | 3 |
| Software Configuration | 3 |
| Approvals | 4 |

2 Specifications

| | |
|---------|---|
| General | 5 |
| Inputs | 5 |
| Outputs | 5 |

3 Installation

| | |
|---|----|
| Panel Mounting | 7 |
| Electrical Connection | 8 |
| Rear Panel Connections | 8 |
| Terminal Designations | 8 |
| Inputs | 9 |
| Analog Input Connections | 9 |
| Logic Input Connection | 9 |
| Outputs | 10 |
| 4-20mA Output Connection | 10 |
| Digital Output Connection | 11 |
| Control Relays | 11 |
| RC Network for Interference Suppression | 12 |
| Communications | 12 |
| RS-232 Port | 12 |
| Infra-red Port (Display Panel Option) | 13 |
| RS-485 Port | 13 |
| Earthing and Shielding | 14 |

4 Operation

| | |
|--------------------------|----|
| Front Panel Operation | 15 |
| Default Variable | 15 |
| Status Lamps | 15 |
| Front Panel Keys | 16 |
| Main Menu Items | 16 |
| Setting the Batch Preset | 17 |
| Data Logs | 17 |
| Model Information | 19 |

| | |
|--|----|
| Starting a Batch | 19 |
| Stopping a Batch | 20 |
| Resetting a Batch | 20 |
| Logic Input Control | 20 |
| Batch Errors | 20 |
| Batch Processes | 21 |
| 5 Instrument Calibration | |
| Introduction | 23 |
| Calibration View Mode | 23 |
| Calibration Set Mode | 24 |
| Changing the Instrument Settings | 25 |
| Calibration Menu Tree | 26 |
| Instrument Settings | 28 |
| Units of Measurement | 28 |
| Parameters | 29 |
| Inputs | 31 |
| Outputs | 34 |
| Communications | 36 |
| Time Settings and Data Logging | 37 |
| General Setup Parameters | 39 |
| Test Menu | 40 |
| System Messages | 41 |
| Error Messages | 41 |
| Warning Messages | 42 |
| 6 Communications | |
| Overview | 43 |
| Hardware Interconnection | 43 |
| Protocols | 45 |
| Simple ASCII Protocol | 45 |
| Requests Format | 46 |
| Instrument Responses | 47 |
| Corrupted or Invalid Requests | 50 |
| Modbus RTU Protocol | 51 |
| List of Data Registers | 52 |
| Printer Protocol | 56 |
| Types of Printouts | 56 |
| Printer Data Control | 59 |
| Appendix A Model Numbers | |
| Product Codes | 61 |
| Custom Version Codes | 62 |
| Application Information Code | 62 |
| Appendix B Units of Measurement | |
| Available Units of Measurement | 64 |
| Index | 65 |

List of Figures

| | | |
|----|--|----|
| 1 | 500 Series Instrument Panel Mounting | 7 |
| 2 | Rear Panel Connections | 8 |
| 3 | Externally Powered Current Loop | 9 |
| 4 | Internally Powered Current Loops | 9 |
| 5 | Output 4-20mA Connection Diagram | 10 |
| 6 | Output Pulse Connection Diagram | 11 |
| 7 | External Relay Connection Diagram | 12 |
| 8 | RS-485 Interface Connections | 13 |
| 9 | Batch Operation with Manual or Automatic Reset | 21 |
| 10 | Batch Operation with Automatic Restart | 22 |
| 11 | Calibration Menu Tree Sheet 1 | 26 |
| 12 | Calibration Menu Tree Sheet 2 | 27 |
| 13 | RS-232 Cable Connections to a Computer | 44 |
| 14 | RS-485 Connections | 44 |

Chapter 1

Introduction

Features

- Tailored for volumetric analog input such as vortex flowmeters
- Single or Dual stage control
- Quick access to common batch quantities
- No-flow, leakage and overflow error detection
- Remote RUN/STOP/RESET
- Allows for non-linear correction
- Storage of 100 transactions with time and date stamp
- Selection of second language and user tags
- Infra-red communications port on front panel
- Pulse width and scaling of pulse output
- 4-20mA retransmission
- Selectable protocols on serial ports including Modbus RTU and Printer output
- Front panel adjustment of 8-24V DC output voltage
- Backlit display
- LCD backup

Overview

The 505 BC02 application is a dual stage batch controller for reliable measurement of preset quantities using a volumetric analog input. Used as a single or dual stage controller it is suitable for fast batch applications.

It provides the operator with clear local readout and can be controlled via communications in more automated systems. There is quick access to commonly used preset values directly from the front panel if access has been authorized. Automatic overrun compensation caters for system delays such as valve closure for precise volumes.

The analog input can be scaled as well as having filtering, non-linear correction and cutoff points applied to the signal.

Calculations

To derive the flow rate, the analog input is normalised to a value (A) between 0 and 1.

$$volumeflow = (V_{fmax} - V_{fmin})A + V_{fmin}$$

$$volume = \int (volumeflow \cdot \Delta t)$$

Automatic overrun compensation calculates the new valve closure point to ensure correct delivery by averaging the overrun amount from the last three complete batches.

The overrun compensation value is valid for a new preset value provided the stored overrun is less than 20% of the new preset.

Analog Input Scaling

The analog inputs in this instrument are scaled by the following general formula:

$$f(A) = P_{min} + (P_{max} - P_{min}) \cdot A^*$$

where:

P_{min} = minimum point (equivalent to offset)

P_{max} = maximum point ($P_{max} - P_{min}$ is equivalent to span)

A^* = normalised signal (0 to 1) with correction applied for a flow input

Correction Type

- LINEAR: $A^* = A$ when the instrument is not required to apply correction
- NON-LINEAR: $A^* = A_C$ when the instrument applies correction from the points in the correction table

Displayed Information

The front panel display shows the current values of the input variables and the results of the calculations.

The instrument can be supplied with a real-time clock for storage of up to 100 transactions with time and date stamps.

Main Menu Variables

| Main Menu Variables | Default Units | Variable Type |
|---------------------|---------------|---------------|
| Volume | Ltr | Total |
| Volume Flowrate | L/min | Rate |

Refer to [Available Units of Measurement](#) on page 64 for the list of available units.

Communications

There are three communication ports available as follows:

- RS-232 port (standard)
- RS-485 port (standard)
- Infra-red port (on front panel - display panel option)

The ports are available for remote data reading, printouts and for initial application loading of the instrument.

Retransmission & Control Outputs

The instrument can retransmit any main-menu variable. The digital outputs can retransmit totals as pulses or operate as logic levels for control or error outputs. If the instrument has the advanced option, it outputs rates as a 4-20mA signal.

Relay Outputs

The relay outputs 1 and 2 are used to control the flow of product for each delivery. These contacts are normally open and can be used to drive external relays, valves, pump circuits etc.

Software Configuration

The instrument can be further tailored to suit specific application needs including units of measurement, custom tags, second language or access levels. A distributor can configure these requirements before delivery.

Instrument parameters including units of measurement can be programmed in the field, according to the user-access levels assigned to parameters by the distributor.

All set-up parameters, totals and logged data are stored in non-volatile memory with at least 30 years retention.

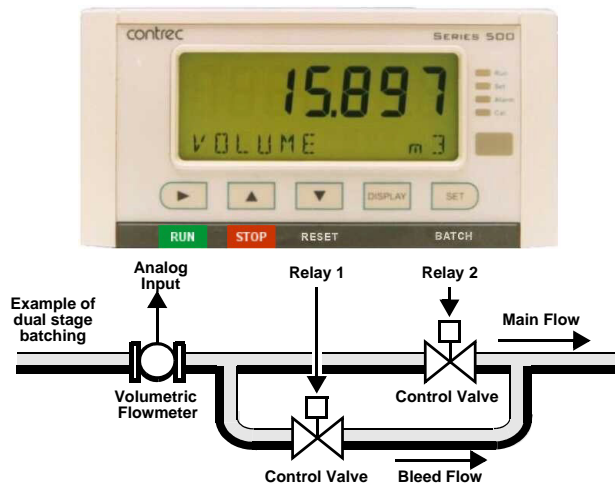

Approvals

This instrument conforms to the EMC-Directive of the Council of European Communities 89/336/EEC and the following standards:

- Generic Emission Standard EN 50081-1 Residential, Commercial & Light Industry Environment.
- Generic Emission Standard EN 50081-2 Industrial Environment.
- Generic Immunity Standard EN 50082-1 Residential, Commercial & Light Industry Environment.
- Generic Immunity Standard EN 50082-2 Industrial Environment.

In order to comply with these standards, the wiring instructions in [Chapter 3 - Installation](#) must be followed.

Chapter 2

Specifications

General

| Operating Environment | |
|-----------------------|--|
| Temperature | 0°C to +60°C (conformal coating) +5°C to +40°C (no coating) |
| Humidity | 0 to 95% non condensing (conformal coating) 5% to 85% non condensing (no coating) |
| Power Supply | 95...135 V AC or 190...260 V AC or 12...28 V DC |
| Consumption | Typically 6W |
| Protection | Sealed to IP65 (Nema 4X) when panel mounted |
| Dimensions | 147mm (5.8") width 74mm (2.9") height 167mm (6.6") depth |

| Display | |
|--------------------|---|
| Type | LCD with 7-digit numeric display and 11-character alphanumeric display (backlit option) |
| Digits | 15.5mm (0.6") high |
| Characters | 6mm (0.24") high |
| LCD Backup | Last data visible for 15min after power down (optional) |
| Update Rate | 0.3 second |

| Non-volatile Memory | |
|---------------------|------------------------|
| Retention | > 30 years |
| Data Stored | Setup, Totals and Logs |

| Approvals | |
|---------------------|--|
| Interference | CE compliance |
| Enclosure | ATEX, FM, CSA and SAA approved enclosures available for hazardous areas |

| Real Time Clock (Optional) | |
|----------------------------|--------------------------------------|
| Battery Type | 3 volts Lithium button cell (CR2032) |
| Battery Life | 5 years (typical) |

Inputs

| 4-20mA Input | |
|----------------------|---|
| Overcurrent | 100mA absolute maximum rating |
| Impedance | 250 ohms (to common signal ground) |
| Accuracy | 0.1% typical full scale (20°C) 0.2% (full temperature range) |
| Non-linearity | Up to 20 correction points (flow inputs) |

| Remote Logic Inputs | |
|---------------------|--------------------------------------|
| Signal Type | Voltage free contact, open collector |

Outputs

| Relay Output | |
|-----------------------|-----------------------------------|
| No. of Outputs | 2 relays |
| Voltage | 250 volts AC, 30 volts DC maximum |
| Current | 3A maximum |

| Communication Ports | |
|---------------------|---|
| Ports | RS-232 port RS-485 port Infra-red port (optional) |
| Baud Rate | 2400 to 19200 baud |
| Parity | Odd, even or none |
| Stop Bits | 1 or 2 |
| Protocols | ASCII, Modbus RTU, Printer (RS232) |

| Transducer Supply | |
|-------------------|---------------------------------|
| Voltage | 8 to 24 volts DC, programmable |
| Current | 70mA @ 24V, 120mA @ 12V maximum |
| Protection | Power limited output |

| Pulse/Digital Output | |
|----------------------|--|
| Signal Type | Open collector, non-isolated |
| Switching | 200mA, 30 volts DC maximum |
| Saturation | 0.8 volts maximum |
| Pulse Width | Programmable: 10, 20, 50, 100, 200 or 500ms |

4-20mA Output (Optional)

| | |
|-------------------|---|
| Supply | 24 volts DC internal, non-isolated |
| Resolution | 0.05% full scale |
| Accuracy | 0.05% full scale (20°C) 0.1% (full temperature range, typical) |

Important: Specifications are subject to change without notice.

Chapter 3

Installation

Panel Mounting

The instrument should be located in an area with a clean, dry atmosphere that is also relatively free of shock and vibration.

The standard mounting procedure is panel mounting in a cutout that is 139mm wide by 67mm high. Two side clips secure the unit into the panel.

Figure 1 Figure 2 shows the panel mounting requirements for the 500 Series Instrument.

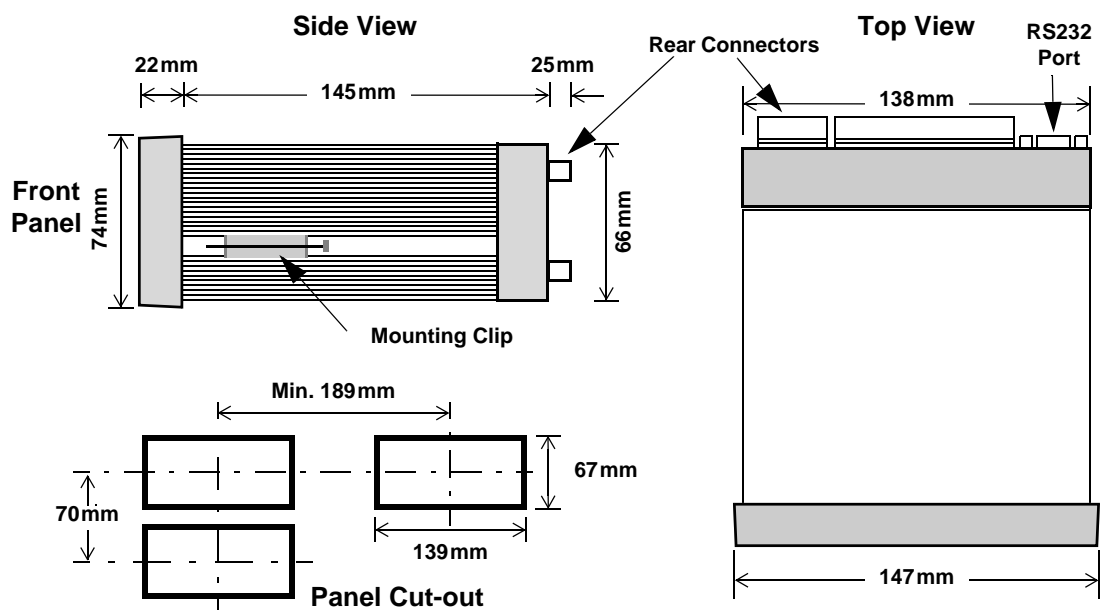

Figure 1 500 Series Instrument Panel Mounting

Electrical Connection

Rear Panel Connections

Figure 2 shows the connections on the rear panel of the instrument.

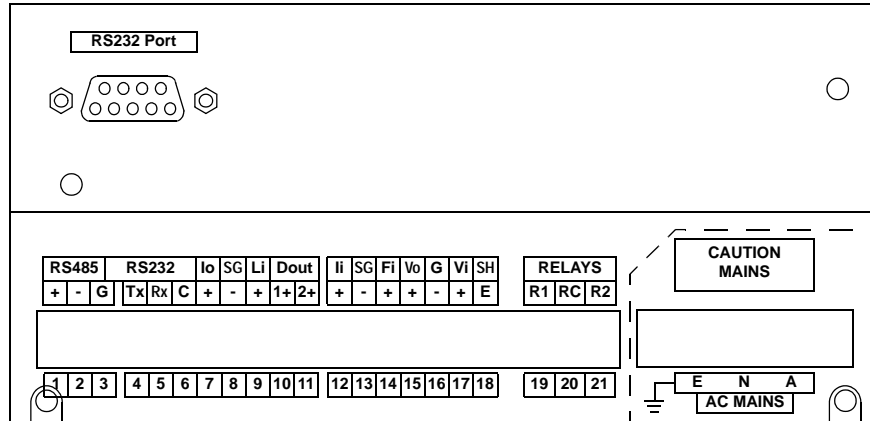

Figure 2 Rear Panel Connections

Terminal Designations

| Terminal Label | Designation | Comment | | |
|----------------|-------------|----------------------|----------------------|---------------------------------|
| 1 | RS485 + | RS485 (+) | | |
| 2 | RS485 - | RS485 (-) | | |
| 3 | G | Comms ground | | |
| 4 | Tx | RS232 data out | | |
| 5 | Rx | RS232 data in | | |
| 6 | C | CTS (Clear to send) | | |
| 7 | Io + | 4-20mA output | Advanced option | |
| 8 | SG - | Signal Ground 0V | | |
| 9 | Li + | Logic input | Remote run | |
| 10 | D OUT | 1+ | Open collector o/p 1 | Digital outputs |
| 11 | | 2+ | Open collector o/p 2 | |
| 12 | li + | 4-20mA input | Volumetric flow | |
| 13 | SG - | Signal Ground 0V | | |
| 14 | Fi + | Signal input | Remote stop/reset | |
| 15 | Vo + | 8-24 volts DC output | 70mA power limited | |
| 16 | G - | DC Ground | DC power in 12-28V | |
| 17 | Vi + | DC power input | | |
| 18 | SH E | Shield terminal | | |
| 19 | RELAYS | R1 | Relay 1 | Single stage |
| 20 | | RC | Relay Common | Dual stage |
| 21 | | R2 | Relay 2 | |
| E | AC MAINS | E | Mains ground | AC power in 95-135V or 190-260V |
| N | | N | Mains neutral | |
| A | | A | Mains active | |
| RS232 port | | 9-pin serial port | Extra option | |

Inputs

Analog Input Connections

The analog input (Ii) can accept current signals from 4 to 20mA.

CAUTION

Applying levels of input current above the absolute maximum rating (100mA) may cause permanent damage to the input circuitry.

4-20mA Inputs

For externally powered current loops, connect each transmitter to a pair of input terminals as shown in Figure 3. [Terminal Designations](#) on page 8 for specific terminal numbers for this application.

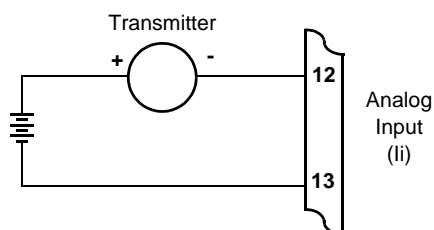

Figure 3 Externally Powered Current Loop

The internal overload-protected power supply has sufficient power for three current loops at 24V DC (more current loops can be supplied by using a reduced voltage setting). Connect internally powered current loops as shown in Figure 4.

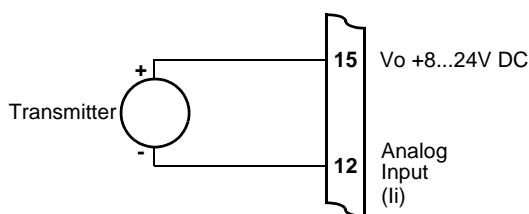

Figure 4 Internally Powered Current Loops

Logic Input Connection

These inputs are designed to be connected to open collector signals or a voltage free contact switch. A minimum activation time of 300mS is required to guarantee reading of an input.

Remote Run Input

A remote push-button key can be connected to the Logic Input (Li, terminal 9) as shown below.

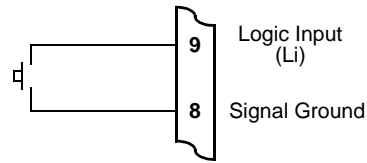

Remote Stop/Reset Input

A remote push-button key can be connected to the multipurpose Signal Input (Fi, terminal 14) as shown below. A momentary press of the remote key is recognised as a Stop signal, while a press and hold for 2 seconds is recognised as a Reset.

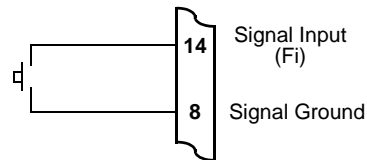

Outputs

The basic instrument has two digital outputs. The advanced option also provides a 4-20mA output port.

4-20mA Output Connection

Figure 5 shows the connections for a 4-20mA output.

Maximum Load Resistance = 900 ohms

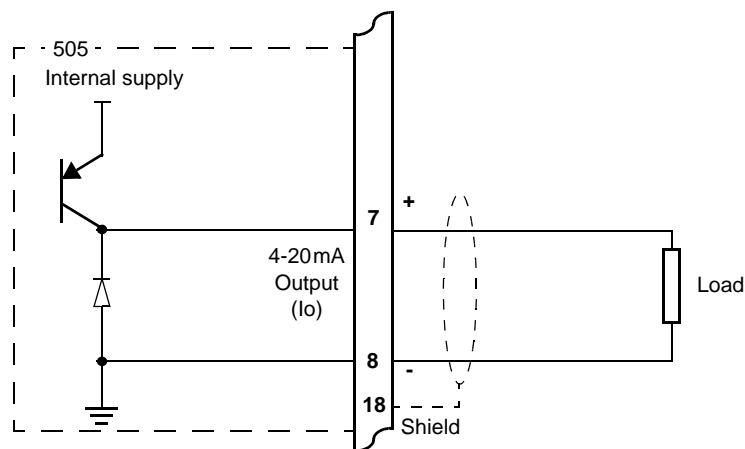

Figure 5 Output 4-20mA Connection Diagram

Digital Output Connection

The digital outputs can be programmed in calibration to function as either a flow error signal, end of batch signal, pump control output or a pulse output for retransmission of totals.

Figure 6 shows a connection example for a pulse output. Output channel 1 uses terminals 10 (+) and 8 (-). Output channel 2 uses terminals 11 (+) and 8 (-).

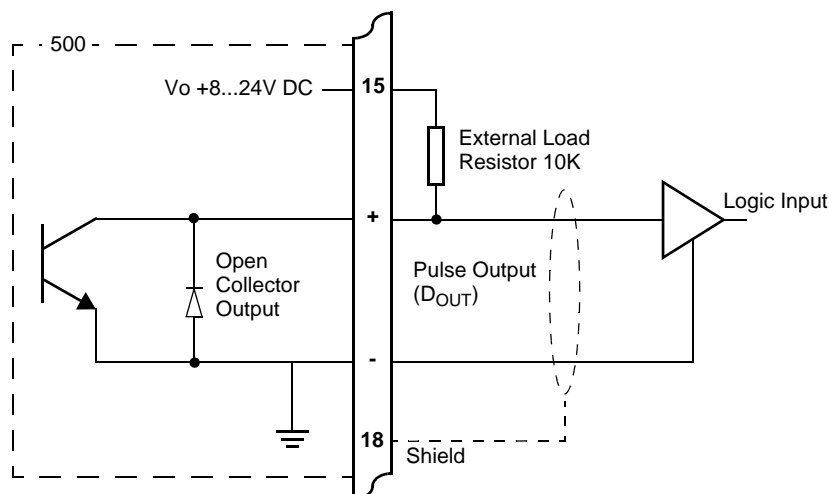

Figure 6 Output Pulse Connection Diagram

Control Relays

The standard instrument has two relays, which are used for the dual stage batch control. The relays can drive external devices such as external relays, valves, pump circuits, lamps, and audible alarms. The operation of each relay can be set in calibration to determine at which points in the process the relays open or close.

The output characteristics of the relays are:

Maximum Voltage 30 volts DC or 250 volts AC
Maximum Current 3 A

Figure 7 shows the connection of the relays.

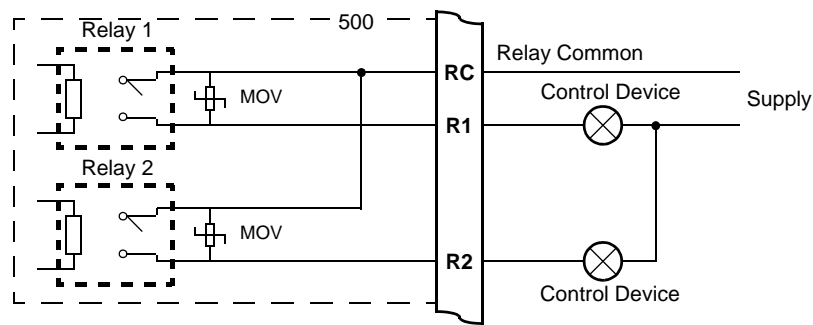

Figure 7 External Relay Connection Diagram

RC Network for Interference Suppression

When driving highly inductive loads with the relay outputs, it is recommended to use RC suppression networks (often called “Snubbers”) for the following reasons:

- To limit the amount of electrical noise caused by arcing across the contacts, which may, in extreme cases, cause the microprocessor to act erratically.
- To protect the relay contacts against premature wear through pitting.

RC suppression networks consist of a capacitor and series resistor and are commonly available in the electrical industry. The values of R and C are dependent entirely on the load. However, if the user is unsure of the type of snubber to use, values of $0.25\mu\text{F}$ and 100Ω will usually suffice. Note that only mains-approved RC suppression networks should be used.

The basic principle of the operation is that the capacitor prevents a series of sparks arcing across the contact as the contact breaks. The series resistor limits the current through the contact when the contact first makes.

Communications

The communication protocols are described in [Communications](#) on page 43.

RS-232 Port

The standard RS-232 port uses terminals 4, 5 and 6 on the rear panel.

The optional extra RS-232 port 9-pin DB female connector has the following pinout:

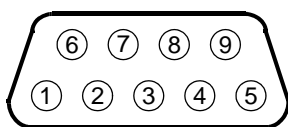

| | |
|-------|----------------------|
| Pin 1 | Not used |
| Pin 2 | Transmit (TxD) |
| Pin 3 | Receive (RxD) |
| Pin 4 | Not used |
| Pin 5 | Ground |
| Pin 6 | Not used |
| Pin 7 | Handshake line (CTS) |
| Pin 8 | RTS Out |
| Pin 9 | Not used |

Note: The instrument does not require a null-modem cable for connection to a personal computer. Refer to [Hardware Interconnection](#) on page 43 for cable termination requirements.

Infra-red Port (Display Panel Option)

The infra-red port is located at the front panel, directly below the row of status indicators. The main function of this port is for retrieving current or logged data with a PC that has an infra-red port.

RS-485 Port

Up to 32 units can be connected to a common RS-485 bus. Each unit has a unique address that the host computer uses to identify each instrument.

Figure 8 shows the connection of several instruments to a computer using the RS-485 port.

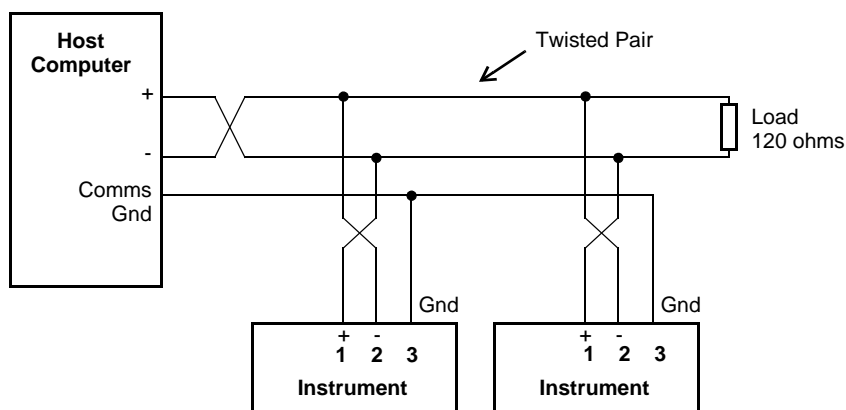

Figure 8 RS-485 Interface Connections

Earthing and Shielding

It is a good practice to use shielded cable for all signal connections to the instrument. Care must be taken to separate signal cables from power cables to minimize interference.

Overall earth should be connected at the instrument end only. This connection should be as short as possible and connected to the earthing point on the rear terminal at pin 18.

Chapter 4

Operation

Front Panel Operation

In normal operation, you press the buttons on the front panel to control the operation of the batch controller or to display the values recorded and calculated by the instrument.

There are several categories of information that the instrument can display:

- Totals
- Rates
- Batch preset values
- Instrument settings

For each total, there is an associated rate as follows:

| Total | Rate |
|--------------|-----------------|
| Volume | Volume Flowrate |

Default Variable

In some applications, a particular variable is of more interest than others, and for this reason a default variable can be assigned during instrument calibration. The default variable is used in the following ways:

- Determines what total the batch and preset is to be based upon.
- Determines what the display returns to if the display timeout option is enabled and no buttons are pressed for the selected period (usually 30 seconds). It also determines what is displayed on power up.

Status Lamps

The status lamps illuminate to show the following conditions:



- Run** Solid led: The instrument has a batch in progress.
Flashing led: Fast, batch paused. Slow, waiting for valves to close.
- Set** Solid led: The instrument is in Calibrate Set mode.
Flashing led: Count down to automatic restart of next batch.
- Alarm** The instrument has an error, as indicated on the display panel.
- Cal** The instrument is in Calibrate View mode.

Front Panel Keys

- RUN** Press the **RUN** key to start or resume a batch. The run led will illuminate.
- STOP** Press the **STOP** key to halt a current batch. The instrument will go into pause mode and the run led will flash at a steady pace. The incomplete batch can be resumed. Also used to stop the next batch if in automatic restart count down.
- RESET** Use the **RESET** key to clear the batch totals or to initiate a printout if the printer option has been selected. The print is activated with a single press while the reset of the totals requires a press and hold for two seconds.

The instrument makes three beeps when it resets the totals and two beeps when a printout is started.

- DISPLAY** Press the **DISPLAY** key to step or scroll through the main menu items.
- BATCH** Hold the **BATCH** key to display the current batch preset value. Continue to hold for two seconds to enter edit mode for the preset if access is authorised. Pressing the **BATCH** key briefly displays the accumulated total.

Main Menu Items

The main menu in this instrument consists of the following items. The **DISPLAY** key is used to step or scroll through the list. The full menu can only be viewed if the batch controller has been stopped and reset.

| DISPLAY ↓ | Description | Options |
|---------------------|---|--|
| VOLUME | Volume | Hold the SET key to display (or edit) the batch preset or briefly press to view the accum total |
| V-FLW | Volume flowrate | |
| REPORT PRINT | Only shown if print option is selected | Hold the SET key to print log report as defined in the TM/LOG section of calibration. |
| LOGGED DATA | Only shown if real-time clock option is installed | Hold the SET key to display data logs as described in Data Logs on page 17. |

| <div style="border: 1px solid black; padding: 2px; display: inline-block;">DISPLAY</div> ↓ | Description | Options |
|---|-------------|---|
| MODEL INFO | | Hold the SET key to display the Model information as described in Model Information on page 19. |
| CAL MENU | | Hold the SET key to enter Calibration View mode as described in Calibration View Mode on page 23. |

Setting the Batch Preset

SET The batch preset can only be set while the instrument is in the non-operational state, i.e. batch is complete or has been stopped and reset. Hold the SET key to display the current preset value while viewing the total variable. The display of the preset will change from view mode to edit mode after 2 seconds if access has been enabled in calibration. Once in edit mode the **Set** indicator will illuminate and the preset value can be changed in the same way as in calibration set mode, see [Changing Numeric Settings](#) on page 25. The SET key is used to exit edit mode.

Limit on Batch Size

To prevent accidental entry of large batch quantities, a maximum batch limit can be programmed during calibration. The operator is then prevented from entering a batch quantity which exceeds this value.

Common Preset Values

If the batching application continually uses a regular set of preset values then quick access can be provided to these. In calibration, there is the opportunity to enter up to 10 commonly used preset values.

These can then be accessed whilst in batch edit mode (described above) by pressing the DISPLAY key. The pre-programmed values will appear in the order they were entered in calibration. The display will step through the presets back to the currently entered value which can still be manually edited. While displaying the desired preset value, press the SET key to accept the value and exit edit mode.

Data Logs

The instrument will log up to 100 deliveries (batches) if the real-time clock option is installed. The logs are taken at the end of each batch or upon reset if a batch has been aborted before the preset total has been reached. Each entry has a log number, a delivery number and a time and date stamp.

When the number of log entries exceeds 99 the oldest log entry is overwritten by the newest one.

View Data Logs

Use the following procedure to view the data that has been logged by the instrument:

1. Press the **DISPLAY** key to scroll through the menu to the **LOGGED DATA** prompt.
2. Hold the **SET** key.

The system displays the most recent log record first. The log record number and corresponding delivery number are shown, for example LR-001 and DEL 1236.

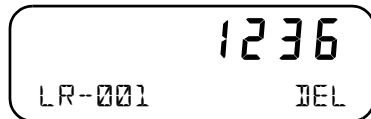

3. Use the **▲** or **▼** keys to scroll to the delivery number or log record of interest.
4. Press the **DISPLAY** key to show the information stored in the selected log record. Each log record consists of:
 - time and date stamp,
 - error code
 - totals for the delivery.
5. While holding the **DISPLAY** key use the **▶** key to step through the stored information.
6. While holding the **DISPLAY** key use the **RESET** key to print the data for the displayed log if the printer option has been selected.

The following example shows the format of the time and date stamp at 15:25 (3:25 pm) on 16 January 2004. The day and month alternate with the year in the bottom right hand corner.

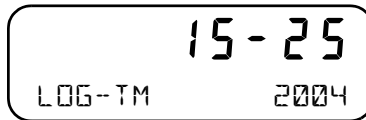
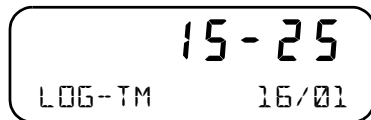

Model Information

The model information items display the hardware, software and application versions of the instrument. This information is mainly for service personnel.

| DISPLAY ↓ | Description |
|--------------------------------|---|
| - 1 - - F - 505 MODEL | The hardware model code. Refer to Product Codes on page 61 for more information. |
| - F BC02 INPUT | The Application number and the assignment of the inputs. Refer to Application Information Code on page 62 for more information. |
| 0 10 1.002 BC02 VERS | The version of software loaded into the instrument. |
| 026357 CUSTOM VERS | The Customer version code for this installation. Refer to Custom Version Codes on page 62 for more information. |
| 123456 ABC123 S/N | The instrument serial number and unit tag. The serial number is on the top line and unit tag is on the bottom left. Both items are entered when the instrument application software is initially loaded. If the unit tag is not used the default tag, UNIT, will be used. |
| 16- 15 EDITED 27/08 2002 | The time and date when the calibration of the instrument was last edited. The format of the time and date is the same as for the data logs. This example shows 16:15 (4:15pm) on the 27th August 2002. This function is available only if the instrument has the real time clock option. |

Press **SET** at any time to exit from the Model information.

Starting a Batch

To start the process the **RUN** key is pressed. The RUN led will illuminate and the instrument will begin to totalise from zero or, if programmed for count down mode, the display will decrement from the preset quantity.

The batch controller's two relays can be used to control the delivery of product. These are energised and de-energised as described below.

Stopping a Batch

The process can be stopped at any time by pressing the **STOP** key. Once the process has been interrupted in this way it can be continued by pressing the **RUN** key or the batch can be aborted and the instrument reset by pressing the **RESET** key.

When the process is interrupted it is in pause mode and the RUN led will flash to prompt the operator to restart or abort the batch.

Resetting a Batch

The instrument can be programmed to reset by different means.

- At the end of a batch, the **RESET** must be pressed to reset the batch total. If the instrument is programmed to count down, the display will revert to the preset value. If it is programmed to count up, the batch total will clear to zero. The next batch can not be started until the previous batch total has been reset.
- If Auto Reset is enabled in the parameters section of calibration, the batch total will automatically reset when the **RUN** key is pressed for the start of the next delivery.

Logic Input Control

This instrument allows for remote operation via the logic inputs on the rear terminals. The logic input have the following functions:

- Logic Input - Remote Run
- Signal Input - Remote Stop/Reset

For connection details, refer to [Logic Input Connection](#) on page 9.

Batch Errors

The instrument has the ability to raise an alarm when it detects a loss of flow, an overflow or a leakage in the system.

- **No Flow Error** - The no flow condition is detected when the flow timeout expires during a delivery. There must not be a period of no flow greater than the timeout value during the delivery.
- **Overflow Error** - The overflow condition is detected when the flow continues longer than the timeout period after the controller has attempted to stop the flow.
- **Leakage Error** - The leakage condition is detected when an amount greater than the acceptable total is received without flow being initiated by the batch controller.

The point at which these errors are detected is dependant on the values programmed into the calibration parameters Batch Flow Timeout and Acceptable Total. The open collector outputs can be assigned to activate whenever one of the flow errors occur. Refer to [Instrument Settings](#) on page 28 for more details.

Batch Processes

The batch controller can be programmed during calibration to operate in various ways including:

- Manual Reset (manual start).
- Automatic Reset (manual start).
- Automatic Restart for continuous batches.

In each of the above modes and configurations the parameters can be programmed to determine the behaviour and timing of relays and output signals. The following figures provide examples of some batch operations. Refer to [Instrument Settings](#) on page 28 for more details.

Manual and Automatic Reset

If Manual Reset the **RESET** key must be pressed at the end of the batch to clear the batch total. This must be done before another batch can be started. If Automatic Reset is programmed, a new batch is commenced each time the **RUN** key is pressed.

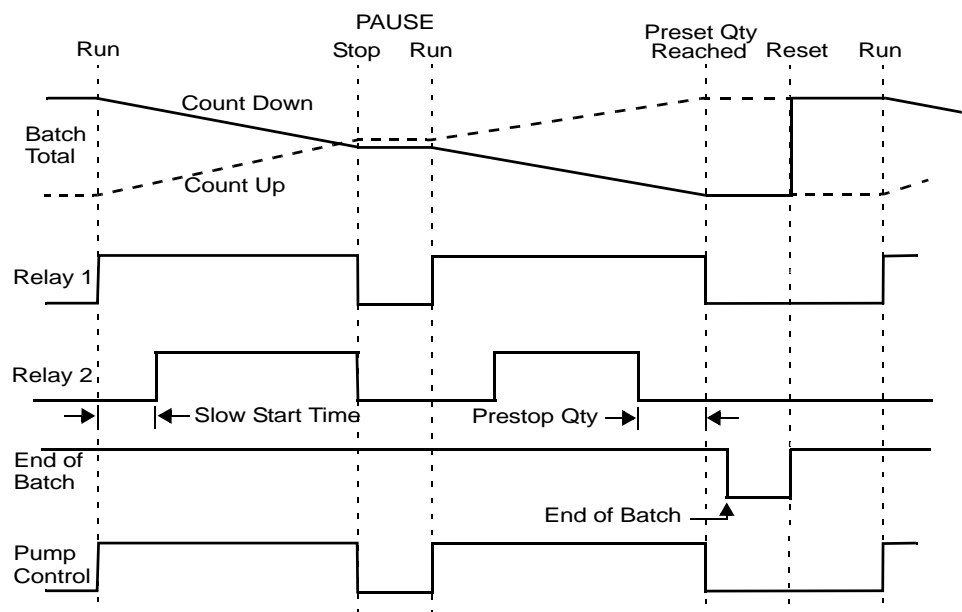

Figure 9 Batch Operation with Manual or Automatic Reset

Automatic Restart

If Automatic Restart is enabled the next batch will commence automatically when the restart timer expires after the end of batch has occurred. The SET led will flash while the instrument is waiting to automatically restart.

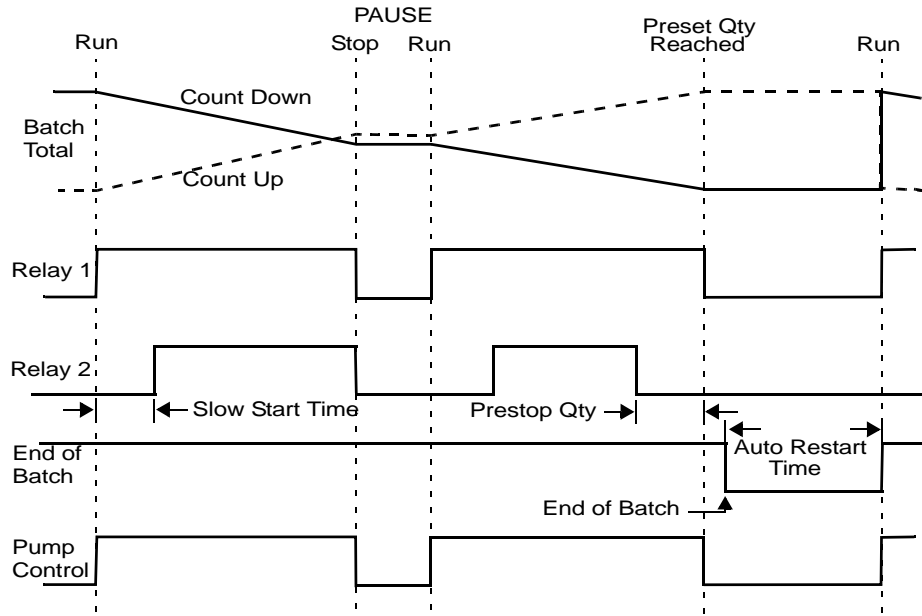

Figure 10 Batch Operation with Automatic Restart

Chapter 5

Instrument Calibration

Introduction

You can view or change the settings of the instrument according to the access level for each parameter as set by the manufacturer. There are four levels of access to the parameters as follows:

- **Not visible** - you cannot display or edit the parameter.
- **Display Only** - you can display the parameter, but you cannot change the setting.
- **Programmable** - you can change the setting of the parameter in Calibration Set mode.
- **Password protected** - you can change the setting of the parameter in Calibration Set mode only if you enter the correct password.

Note: When you enter Calibration Set mode, the instrument requests you to enter a password. You can enter any “incorrect” password to change the settings of the “programmable” parameters. You must enter the correct password to change the password-protected parameters.

Calibration View Mode

Use the following procedure to view the calibration settings of the instrument:

1. Press **DISPLAY** to scroll to the **CFM MENU** prompt.
2. Hold the **SET** key.



The instrument beeps once, illuminates the **Cal** indicator and shows **CFM** on the display panel.

- Press **▶** to scroll through the flashing menu headings.
 - Press **SET** to scroll through submenu items.
 - Press **DISPLAY** to return to the main calibration menu.
3. To exit from the Calibration View mode, press **▶** to scroll to the **END** option and press **SET**.

The instrument returns to Normal Operation mode.

Calibration Set Mode

In Calibration Set mode, you can change the settings of the “programmable” parameters. You must enter the system password to change the setting of the “password-protected” parameters.

Use the following procedure to enter Calibration Set mode:

1. Press **DISPLAY** to scroll to the **FL MENU** prompt.
2. Hold the **SET** key.



The instrument beeps once, illuminates the **Cal** indicator and shows **FL** on the display panel.

3. Press **▶** to select any flashing menu heading except **END**.
4. Hold **SET** for two seconds.
The instrument requests a password.
5. Press **▲** or **▼** to change the value of the current digit. To select the next digit, press **▶**.
6. Press **SET** to accept the password.
 - The instrument makes two beeps for a correct password entry and enables you to change the “programmable” and “password-protected” parameters.
 - The instrument makes one beep for an incorrect password entry and enables you to change only the “programmable” parameters.



The instrument illuminates both the **Cal** and **Set** indicators.

7. Edit the instrument parameters as required. The programmable values are indicated by the flashing display.
 - To change a numerical value, press **▲** to increase a value, or press **▼** to decrease a value. Press a key momentarily to change the value one number at a time. Hold a key to scroll through the numbers. To proceed to next digit, press **▶**.
 - To change an option setting, press **▲** or **▼** to scroll through the options.
8. Press **SET** to accept the currently displayed value and proceed to the next parameter. You can press **DISPLAY** to return to the main calibration menu.
9. To exit from Calibrate Set mode, press **▶** to scroll through the main calibration menu to **END**, then press **SET**. Otherwise, from any menu, you can press and hold **SET** for two seconds.





The instrument makes two beeps and cancels the **Cal** and **Set** indicators.

Changing the Instrument Settings

In Calibration Set mode, the display flashes the item that can be changed. For option settings, the display flashes the complete option. For a numeric parameter, the display flashes one digit at a time, you can change the value of the flashing digit as required, then move the flashing cursor to change another digit.

Note: When you change the setting of a parameter, the instrument records the result as soon as you move to another parameter, or exit from the Calibration Set mode.

Changing Option Settings

When you display an option that can be changed, the entire option flashes on the display, such as the choices of ODD, EVEN or NONE for the communications parity bit checking. Press  or  to change the option. You can “scroll” through the options in either direction to make a selection as shown below.

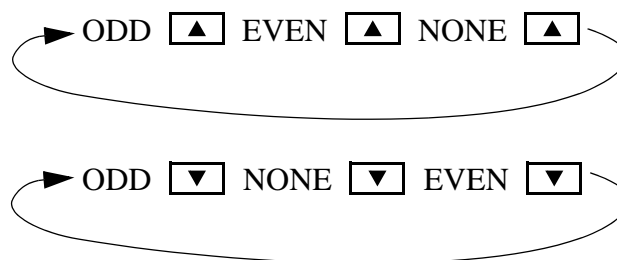

Changing Numeric Settings



The display flashes the digit that can be changed.



Press  to select the digit that you wish to change.

Press  or  to increase or decrease the value of the selected digit.

Changing the Decimal Point

To change the position of the decimal point, press  to move the flashing selection until the decimal point flashes. Press  or  to move the decimal point to the right or left as required.

Units of Measurement

The calibration of some parameters is based on the units that are defined for the relevant variables. These units of measurement can be viewed in the UNITS menu in calibration below.

Calibration Menu Tree

Figure 11 and Figure 12 show the keys for moving around the calibration menu tree in Calibration View or Set mode.

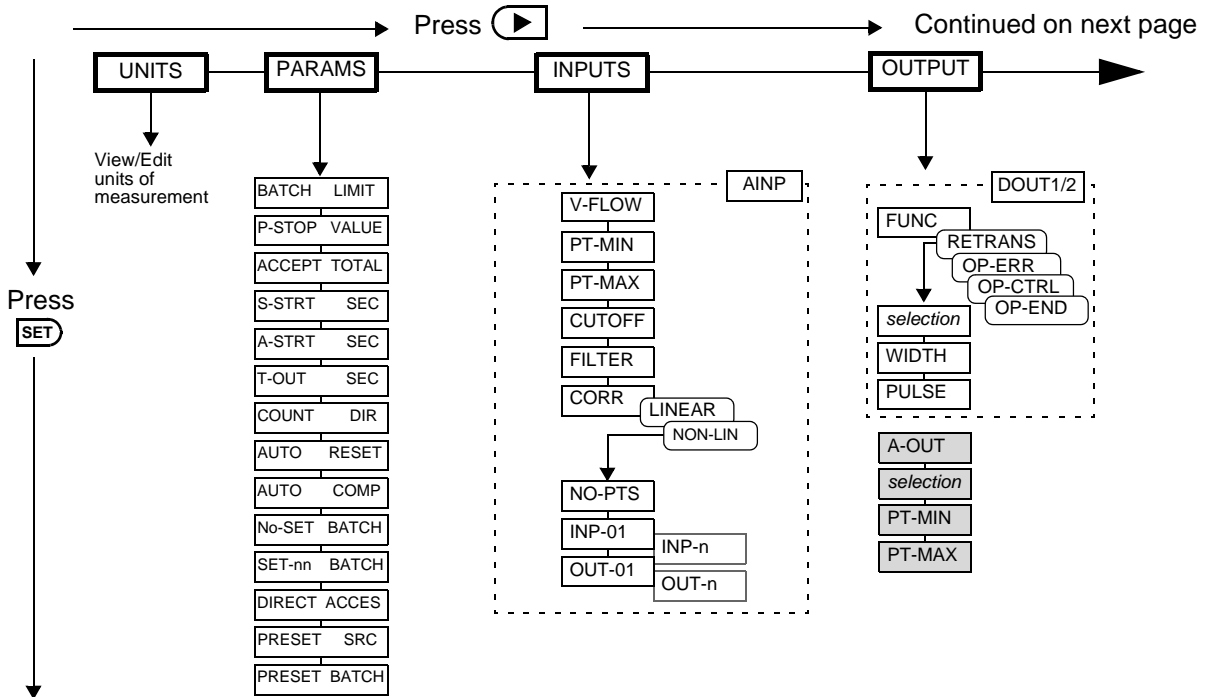

Figure 11 Calibration Menu Tree Sheet 1

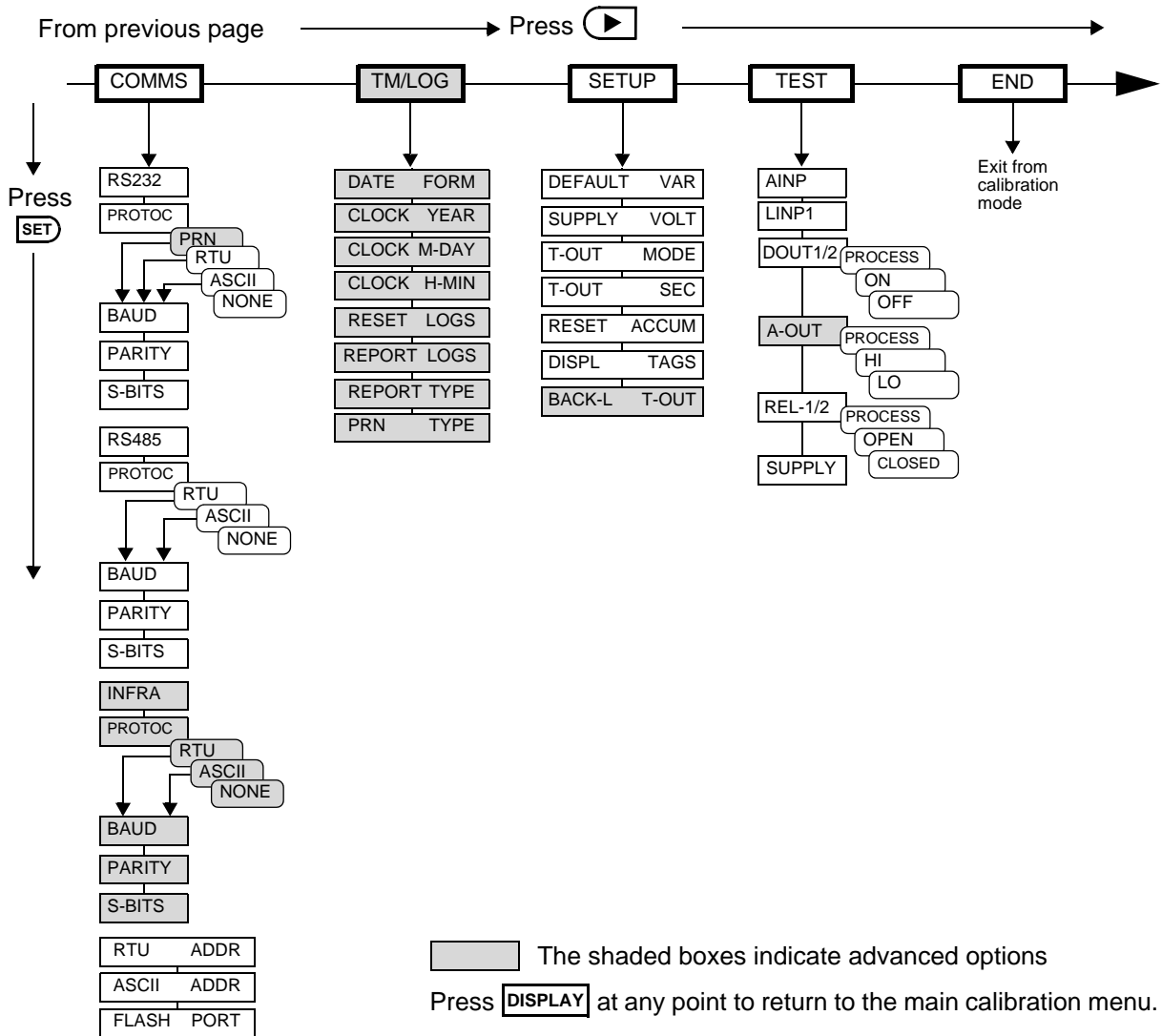

Figure 12 Calibration Menu Tree Sheet 2





Instrument Settings











Units of Measurement

The Units menu allows the units to be viewed and edited if necessary without the reloading of new application software. Any change in units will result in a full reset to initially downloaded settings. Therefore, any required changes to units of measurement should be made before changing any other settings.

| | |
|---------------------------------------|--|
| <p>SET ↓</p> | <p>▶ → UNITS PARAMS INPUTS OUTPUTS COMMS TM/LOG SETUP TEST END</p> |
| <p>ITEM <i>n</i> <i>unit</i></p> | <p>The units for main menu or calibration items can be viewed by pressing the SET key.</p> <p>The units of measurement are password protected. To edit the units the correct password must be entered on entry to EDIT mode.</p> <p>Press ▲ or ▼ to select the required units. Refer to Available Units of Measurement on page 64 for the list of available units.</p> |
| <p>ACCEPT UNITS</p> | <p>The Accept Units prompt will only appear if one or more of the units have been changed.</p> <p>IMPORTANT: Accepting the change of units will initiate a master reset. All calibration parameters will revert to their default value (i.e. those values included in the downloaded instrument software). All totals and any logged information will be cleared.</p> <p>Press ▲ or ▼ to select YES, then press the SET key. The instrument makes three beeps to confirm the reset command.</p> <p>The message -RESET- PLEASE WAIT will be displayed as the instrument exits calibration mode and completes a full re-boot sequence.</p> |

Parameters

|  ↓ |  → UNITS PARAMS INPUTS OUTPUTS COMMS TM/LOG SETUP TEST END |
|---|---|
| BATCH LIMIT | <p>The batch limit determines the maximum batch preset value that can be entered. If a value of zero is entered for this parameter then no limit is applied.</p> <p>Enter the value in the engineering units of the batch preset.</p> |
| P-STOP VALUE | <p>The prestop value determines when relay 2 deactivates as the batch approaches the preset quantity.</p> <p>Enter the value in the engineering units of the batch preset.</p> |
| ACCEPT TOTAL | <p>The acceptable batch total determines when a leakage error is raised. An error is detected if an amount greater than the acceptable total is received without flow being initiated by the batch controller. It also allows small totals due “meter skips” and vibration to be discarded without being considered as a valid delivery.</p> <p>Enter the value in the engineering units of the batch preset.</p> |
| S-START SEC | <p>The batch slow start time determines when relay 2 activates after the start or resumption of a batch.</p> <p>Enter the value in seconds.</p> |
| A-START SEC | <p>The batch automatic restart time determines the time that will elapse between the end of one batch and the start of the next. A value of zero disables the auto restart feature.</p> <p>Enter the value in seconds.</p> |
| T-OUT SEC | <p>The batch flow timeout determines length of no flow time that the instrument will wait during a batch before raising a no flow error. It is also determines when an overflow error is raised if flow does not cease within the timeout period after the controller attempts to stop the flow. A value of zero disables these flow timeout features.</p> <p>Enter the value in seconds.</p> |
| COUNT DIR | <p>The batch count direction determines whether the batch total counts up from zero to the preset value or down from the preset to zero.</p> <p>Press  or  to select UP or DOWN.</p> |

|  ↓ |  → UNITS PARAMS INPUTS OUTPUTS COMMS TM/LOG SETUP TEST END |
|---|---|
| AUTO RESET | <p><i>This parameter is available for viewing and editing only when the batch automatic restart time is set to zero.</i></p> <p>The automatic reset feature allows the previous batch total to be reset automatically when a new batch is started with the RUN key.</p> <p>Press  or  to select ENABLE or DISABLE.</p> |
| AUTO COMP | <p>The batch automatic overrun compensation allows the instrument to automatically compensate for any consistent overrun at the end of the batch. Overrun is typically due to the slowness of a valve to close or a pump to stop on receiving a signal from the batch controller and results in the delivered quantity being greater than the entered preset</p> <p>In calculating the amount to be compensated for the instrument uses the average overrun from the last three batches. An overrun of more than 20% is considered invalid and will not be included in the calculations.</p> <p>Press  or  to select ENABLE or DISABLE.</p> |
| No -SET BATCH | <p>To provide faster access to commonly used preset values a number of batch presets can be preprogrammed into the instrument. This parameter allows the number of batch presets to be entered.</p> <p>Press  or  to select a number between 1 and 10.</p> |
| SET-01 BATCH to SET-n | <p>Enter the commonly used preset values for quick access via the front panel.</p> <p>Enter the value in the engineering units of the batch preset.</p> |
| DIRECT ACCES | <p>If the direct access is enabled then the operator is able to enter edit mode for the preset parameter directly from the main menu by holding the  key while viewing the preset. If disabled the preset can only be changed from within calibration set mode (or via serial communications, see below). Select the direct access mode as required.</p> <p>Press  or  to select ENABLE or DISABLE.</p> |

| SET ↓ | ▶ → UNITS PARAMS INPUTS OUTPUTS COMMS TM/LOG SETUP TEST END |
|--------------|---|
| PRESET SRC | <p>The instrument allows the batch preset value to be changed via either of two methods:</p> <ul style="list-style-type: none"> • USER - The instrument allows the preset value to be changed only by the user via the front panel. • RTU - The instrument allows the preset value to be changed via Modbus RTU communications or by the user via the front panel. <p>Press ▲ or ▼ to select USER or RTU.</p> |
| PRESET BATCH | <p>Enter the batch preset quantity. This setpoint is only available for PRESET batch mode.</p> <p>Enter the value in the engineering units of the assigned variable.</p> |







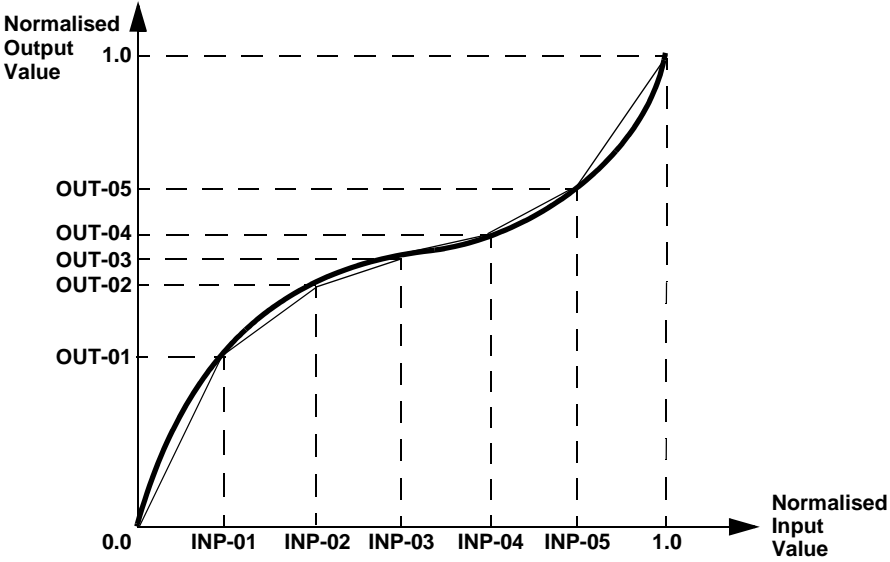



Inputs

| SET ↓ | ▶ → UNITS PARAMS INPUTS OUTPUTS COMMS TM/LOG SETUP TEST END |
|-----------------------|---|
| Analog Input | |
| INPUT V-FLOW AINP | For this application, the Analog Input is assigned to volume flowrate. |
| TYPE AINP | <p>This step identifies the type of analog input source.</p> <p>For model 505 instruments the input is fixed to 4-20mA.</p> |
| PT-MIN AINP PT-MAX | <p>Enter the value of the measured parameter (in the assigned engineering units) that corresponds to the minimum input signal level. The minimum point is commonly set at a base flowrate of 0.0.</p> <p>Enter the value of the measured parameter (in the assigned engineering units) that corresponds to the maximum input signal level. The maximum point is the same as the base value (set at the minimum point) plus the span value.</p> <p>For example, if the source signal is 4mA at a minimum volumetric flowrate of 2m³/M, enter 2 as the minimum point. If the source signal is 20mA at a maximum volumetric flowrate of 250m³/M, enter 250 as the maximum point.</p> |
| CUTOFF AINP | <p>The Cut-off is the lowest value that the instrument reads from the input sensor. The cut-off setting is the percentage of the span of the input values.</p> <p>All inputs at or below the cut-off value are considered negligible to the instrument and are ignored. In this case, the instrument uses the minimum value (set at PT-MIN).</p> |

| SET ↓ | ▶ → UNITS PARAMS INPUTS OUTPUTS COMMS TM/LOG SETUP TEST END | | |
|---|--|------------------------------------|------------------------------------|
| FILTER RINP | <p>Input fluctuations caused by pulsating flow tend to create distortion in the input readings of the rate. The instrument has a digital filter that averages out these fluctuations.</p> <p>As a guide to the degree of filtering to use, the following table shows the response time (in seconds) to reach 90% and 99% of a step change in input.</p> <p>The value A is the filter constant that the user can set.</p> | | |
| | Filter setting A | Seconds to reach 90% of full swing | Seconds to reach 99% of full swing |
| | 0 | 0 | 0 |
| | 2 | 2 | 4 |
| | 4 | 4 | 8 |
| | 6 | 5 | 10 |
| | 10 | 8 | 15 |
| | 15 | 12 | 23 |
| | 20 | 14 | 27 |
| | 25 | 18 | 34 |
| | 35 | 25 | 48 |
| | 45 | 32 | 62 |
| | 60 | 42 | 82 |
| | 75 | 52 | 102 |
| | 90 | 62 | 122 |
| | 99 | 68 | 134 |
| | The input filter range is from 0 to 99. A setting of 0 (zero) means that there is no filtering. | | |
| CORR RINP | <p>Analog input non-linearity can be corrected as follows:</p> <ul style="list-style-type: none"> • LINEAR • NON-LINEAR to use the following linearity correction parameters <p>Use ▲ or ▼ to select LINEAR or NON-LINEAR.</p> | | |

| SET ↓ | ▶ → UNITS PARAMS INPUTS OUTPUTS COMMS TM/LOG SETUP TEST END |
|------------------------------|--|
| NO-PTS RINP | <p><i>This parameter is available for viewing and editing only when the correction type is set to Non-linear.</i></p> <p>Enter the number of non-linearity correction points.</p> <p>Press ▲ or ▼ to select a number between 1 and 20 for the number of correction points.</p> |
| INP--01 RINP to INP--n | <p><i>This parameter is available for viewing and editing only when the correction type is set to Non-linear.</i></p> <p>Enter the normalised input value for the correction point.</p> <p>The instrument uses linear interpolation between the correction points. An input and an output value are entered for each correction point. The values are normalised between the minimum point (0.0) and the maximum point (1.0). Only the points between 0 and 1 are required to be entered and should be entered in ascending order.</p> <p>The following diagram shows a 5 point linearised representation of the input from a hypothetical transmitter. The heavy black line represents the actual input from the transmitter. The light black line is the approximation that the instrument uses.</p>  <p>You can press the DISPLAY key to skip the non-linear points and go to the next item.</p> |
| OUT--01 RINP to OUT--n | <p><i>This parameter is available for viewing and editing only when the correction type is set to Non-linear.</i></p> <p>Enter the normalised output value for the correction point.</p> |

Outputs

|  ↓ |  → UNITS PARAMS INPUTS OUTPUTS COMMS TM/LOG SETUP TEST END |
|---|---|
| FUNC OUT _n | <p>The digital output can function as either a pulse output for retransmission of totals, a no flow error signal, a pump control output or an end of batch signal.</p> <p>Press  or  to select RETRANS, OP-ERR, OP-CTRL or OP-END</p> |
| PULSE OUT _n | <p><i>The Output Assignment and associated parameters are available for viewing and editing only when the Output Functionality has been set for retransmission.</i></p> <p>You can assign any of the “total” main menu variables to a pulse output. The current application may have only one “total” variable, but you can assign it to either or both of the pulse outputs.</p> <p>Press  or  to select the variable that is required as an output.</p> |
| WIDTH OUT _n | <p>Pulse output is usually used to drive remote counters. Set the pulse width (in milliseconds) as required by the remote counter.</p> <p>Press  or  to set to: 10, 20, 50, 100, 200 or 500ms.</p> |
| PULSE OUT _n | <p>The Output Pulse Factor is the scaling factor for the retransmission of the measured total quantity.</p> <p>For example, if “volume” is chosen as an output variable, the engineering unit is cubic metres. Therefore a pulse factor of 1.000 generates one pulse for 1 m³. Similarly, a pulse factor of 3.000 generates one pulse for 3 m³.</p> <p>For more information, see Output Pulse Factor on page 35.</p> <p>The output pulse factor cannot be 0 (zero).</p> |
| 4-20 R-OUT | <p>You can assign any of the “rate” main menu variables to the 4-20mA output.</p> <p>Press  or  to select the variable that is required as an output.</p> |

| SET ↓ | ▶ → UNITS PARAMS INPUTS OUTPUTS COMMS TM/LOG SETUP TEST END |
|--|--|
| PT--MIN A--OUT PT--MAX A--OUT | <p>The output minimum value corresponds to the 4mA point and the output maximum value corresponds to the 20mA point.</p> <p>Setting the output range differently from the input range enables the instrument to amplify the input signal. You can drive a chart recorder that “zooms in” on a specified range of values instead of displaying the full operating range of the transducer.</p> <p>For example, if the minimum point is set to 30m³/min and the maximum point is set to 100m³/min, the 4 to 20mA range would reflect the volumetric flow rate range of 30 to 100m³/min. At rates above the maximum and below the minimum points, the output remains at 20mA and 4mA respectively.</p> |

Output Pulse Factor

Increasing the output pulse width reduces the maximum frequency at which a total variable can be retransmitted. Pulses will be missed if the output cannot “keep up” with the rate of total counts. You can use the output pulse factor to ensure that this maximum is not reached.

The maximum pulse output frequency is determined by:

$$\frac{1000}{(2 \times \text{pulse width in ms})} \text{ Hz}$$

The minimum pulse factor required is determined by:

$$\frac{\text{max rate of total}}{\text{max pulse output frequency}}$$

For example: To calculate the required pulse factor to avoid losing counts in retransmission if a total counts at a maximum rate of 75 units/sec (Hz) and the required pulse width of a remote counter is at least 50ms:

The maximum pulse output frequency is: $\frac{1000}{2 \times 50} = 10\text{Hz}$

The minimum pulse factor for that frequency is: $\frac{75}{10} = 7.5$

Communications

The instrument has three communication ports:

- **RS-232 Port** - Three terminals on the rear of the instrument. There is also an optional 9-pin female connector on the rear panel of the instrument.
- **Infra-red Port** - (Display panel option only) Located on the front panel, below the status indicators.
- **RS-485 Port** - Terminals on the rear panel.

| SET ↓ | ▶ → UNITS PARAMS INPUTS OUPUTS COMMS TM/LOG SETUP TEST END |
|--------------------------------|--|
| PROTOC RS232 RS485 INFRA | <p>The Communications Protocol for each communication port can be set to either ASCII or Modbus RTU. A protocol cannot be assigned to more than one port at a time. If a port is not being used, set the protocol to NONE.</p> <p>If the Real Time Clock option installed the RS232 port can also be assigned the printer protocol (PRN).</p> <p>For the selected port, press ▲ or ▼ to select NONE, RTU, ASCII or PRN (RS232 only).</p> |
| BAUD RS232 RS485 INFRA | <p>The Baud setting is the speed of the communication port in data bits per second.</p> <p>The baud rate of the instrument must match the baud rate of the communication device that the instrument is connected to.</p> <p>Use ▲ or ▼ to select 2400, 4800, 9600 or 19200 baud.</p> |
| PARITY RS232 RS485 INFRA | <p>The Parity bit offers a small amount of error checking, to help detect data corruption that might occur during transmission.</p> <p>The parity bit setting of the instrument must match the parity bit checking of the communication device that the instrument is connected to.</p> <p>Press ▲ or ▼ to select EVEN, ODD, or NONE.</p> |
| S-BITS RS232 RS485 INFRA | <p>The Stop bit indicates the end of a transmission. Stop bits can be 1 or 2 bit periods in length. The stop bit setting of the instrument must match the stop bit setting of the communication device that the instrument is connected to.</p> <p>Press ▲ or ▼ to select 1 or 2 stop bits.</p> |

| <input type="button" value="SET"/> ↓ | <input type="button" value="▶"/> → UNITS PARAMS INPUTS OUPUTS COMMS TM/LOG SETUP TEST END |
|--------------------------------------|--|
| RTU ADDR | <p>The Modbus RTU protocol address must be in the range of 1 to 247. When multiple instruments (slaves) are connected to one communication device (master), each assigned address must be unique.</p> <p>Note: The master device uses the RTU address 0 (zero) for broadcasting to all connected slave units.</p> |
| ASCII ADDR | <p>The ASCII protocol address identifies each communicating device.</p> <p>The address must be in the range of 1 to 255. When multiple instruments (slaves) are connected to one computer (master), each assigned address must be unique.</p> |
| FLASH PORT | <p>The Flash Driver Port assignment defines the communication port for downloading software into the instrument.</p> <p>The default setting of this assignment is the RS-232 port.</p> <p>Press <input type="button" value="▲"/> or <input type="button" value="▼"/> to select RS-232, RS-485, or INFRA.</p> |

Time Settings and Data Logging

Instrument Clock

Note: The real-time clock is part of the advanced option package.

The instrument has a real-time clock for recording logged events. The clock displays the time and the date. The date format can be set to European format (day/month/year) or American format (month/day/year). The time clock uses the 24-hour format.

The clock will continue to operate for up to 5 years (typically) on the internal battery if there is no power connected to the instrument. Therefore, after an interruption to the power supply, the instrument recommences normal operation although there will be no data recorded during the period without a power supply.

Note: If there is an interruption to the power supply and the battery has failed, the instrument displays an error message when the power supply is restored. In this case, you should set the current time and date so that the instrument continues to log data at the correct times.

Data Logging

The instrument will log a total of 100 deliveries (batches) if the real-time clock option is installed. The logs are taken at the end of each batch or upon reset if a batch has been aborted before the preset total has been reached.

| SET ↓ | ▶ → UNITS PARAMS INPUTS OUPUTS COMMS TM/LOG SETUP TEST END |
|-------------------|--|
| DATE FORM | <p>Clock Date Format</p> <p>The European date format is: dd/mm/yyyy or (Day-Month).</p> <p>The American date format is: mm/dd/yyyy or (Month-Day).</p> <p>Press ▲ or ▼ to select DAY-M or M-DAY</p> |
| CLOCK YEAR | The Clock Year defines the current year for the real-time clock. |
| CLOCK M-DAY | The Clock M-DAY setting defines the current month and date for the real-time clock. This parameter is programmed in Month-Day format for both European and American date formats. |
| CLOCK H-MIN | The Clock H-MIN setting is the current time in hours and minutes for the real-time clock. |
| RESET LOGS | <p>Reset the logged data. You may need to reset (clear) the logged data if you change the time/log settings.</p> <p>Press ▲ or ▼ to select YES, then press the SET key. The instrument makes three beeps to confirm the reset command.</p> |
| REPORT LOGS | <p>The Printer Protocol Report Logs defines the number of latest logs to be included into a printable report.</p> <p>Enter the number of logs between 0 and 99.</p> |
| REPORT TYPE | <p>The Printer Protocol Report Type determines the nature of the printout from the REPORT PRINT - HOLD.SET prompt in the main menu. The following report types available in this instrument are:</p> <ul style="list-style-type: none"> • REP-10 Preset number of latest logs <p>Press ▲ or ▼ to select Report Type.</p> |
| PRN TYPE | <p>The Printer Protocol Printer Type allows the nature of the printer being used to be specified. The following printer types available in this instrument are:</p> <ul style="list-style-type: none"> • PRN-01 Generic computer printer • PRN-02 Generic roll printer (prints first line first) • PRN-03 Slip printer TM295 <p>Press ▲ or ▼ to select Printer Type.</p> |

General Setup Parameters

| SET ↓ | ▶ → UNITS PARAMS INPUTS OUPUTS COMMS TM/LOG SETUP TEST END |
|-------------|---|
| DEFAULT VAR | <p>Select the main menu variable to display on power up or when the display timeout period has elapsed if it is enabled.</p> <p>Press ▲ or ▼ to select the default variable display.</p> |
| SUPPLY VOLT | <p>The instrument provides a power-limited supply for external transducers.</p> <p>Press ▲ or ▼ to set the transducer supply voltage between 8 and 24 volts DC as required.</p> |
| T-OUT MODE | <p>If the Display Timeout mode is enabled, and there is no user activity for the defined timeout period, the display panel returns to the default display.</p> <p>This function is useful for the following reasons:</p> <ul style="list-style-type: none"> • to return the display to a preferred variable after the user has finished reading other information, • to cancel the calibration mode and return to the default display if the user does not exit from the calibration mode for any reason. <p>Press ▲ or ▼ to select the display timeout function as follows:</p> <ul style="list-style-type: none"> • DISABLE - Timeout is completely disabled. • EN DISP - Timeout is enabled during Normal mode and Calibration View mode. • EN EDIT - Timeout is enabled during Calibration Set mode. • EN ALL - Timeout is enabled for all modes. |
| T-OUT SEC | <p>The Display Timeout period defines the delay for the Display Timeout mode if it is enabled.</p> <p>The display timeout period can be from 10 to 99 seconds.</p> |
| RESET ACCUM | <p>The Reset Accumulated Totals function clears all of the accumulated totals and the non-accumulated totals.</p> <p>Press ▲ or ▼ to select YES, then press the SET key. The instrument makes three beeps to confirm the reset command.</p> |

| SET ↓ | ▶ → UNITS PARAMS INPUTS OUPUTS COMMS TM/LOG SETUP TEST END |
|--------------|---|
| DISPL TAGS | <p>The Display Tags option determines whether the instrument displays the default display tags or the user-defined tags. The display tag setting also defines whether the instrument displays the default error and warning messages, or the user-defined messages.</p> <p>Note: The user-defined tags can be entered into the instrument only by the manufacturer or the distributor.</p> <p>Press ▲ or ▼ to select the Display Tags option as follows:</p> <ul style="list-style-type: none"> • DEFAULT - the instrument displays the default (English) tags • USER - the instrument displays the user-defined tags. |
| BACK-L T-OUT | <p>If the backlight timeout is enabled, and there is no user activity (any keys pressed) for a period of 10 seconds, the display backlight switches off to save power. The backlight switches on when a key is pressed. Select the backlight timeout mode as required.</p> <p>Press ▲ or ▼ to select ENABLE or DISABLE.</p> |

Test Menu

The Test menu enables you to view the inputs and outputs to and from the instrument.

In Calibration Set mode, (by entering the system password) you can control the outputs and the alarms as described in the table below.

| SET ↓ | ▶ → UNITS PARAMS INPUTS OUPUTS COMMS TM/LOG SETUP TEST END |
|--------------------------|--|
| AINP mA | The current of the signal input to AINP is displayed in milliamps. |
| LINP1 STATE | You can view the state of the logic input. If the input is an open contact or inactive it will display HI . If the input is a closed contact or active it will display LO . |
| OUT1 STATE to OUT2 | <p>You can control the state of the outputs. Press the ▲ or ▼ keys to set the output state as follows:</p> <ul style="list-style-type: none"> • PROCESS - the output depends on the current values of the inputs and the calculations that the instrument performs. • ON - the output is a pulse train with a pulse width as set for the particular output in the Outputs menu. • OFF - no output. |

| SET ↓ | ▶ → UNITS PARAMS INPUTS OUPUTS COMMS TM/LOG SETUP TEST END |
|----------------------------|---|
| R-OUT STATE | <p>You can control the state of the outputs. Press the ▲ or ▼ keys to set the output state as follows:</p> <ul style="list-style-type: none"> • PROCESS - the output depends on the current values of the inputs and the calculations that the instrument performs. • HI - the output is set to 20mA. • LO - the output is set to 4mA. |
| REL-1 STATE to REL-2 | <p>You can control the state of the relays. Press the ▲ or ▼ keys to set the selected relay as follows:</p> <ul style="list-style-type: none"> • PROCESS - the relay condition operates according to the current batch status and the relay settings as programmed. • OPEN - the relay output contacts are set to “open”. • CLOSED - the relay output contacts are set to “closed”. |
| SUPPLY ✓ | <p>You can display the actual DC output supply voltage, which may help with troubleshooting.</p> <p>If the actual supply voltage is lower than the preset value (refer to General Setup Parameters on page 39) it may indicate that the output is overloaded.</p> |

System Messages

The instrument displays messages for defined events and fault conditions.

The manufacturer or distributor can enter user-defined text for the messages. This user-defined text is displayed, instead of the default (English) messages, when the Display Tags option in the Setup menu is set to USER.

Error Messages

The system displays error messages as described in the following table:

| Error Messages | Description |
|---------------------|---|
| CPU Card Failure | There are failed components on the CPU card and technical support is required. |
| Power Supply is Low | The input and/or output power supply voltage is too low, ensure that: (a) input power supply voltage is within the specified range (b) output power supply is not overloaded. |

| Error Messages | Description |
|-------------------------------|---|
| New/Failed Battery - Set Time | <p>The real-time clock has lost the correct time because the battery has failed, or there is a new battery. Set the current time and date (in the TM/LOG menu) to clear the error message and to continue data logging at the correct times.</p> <p>Note: The instrument can continue operating with a failed battery, but the correct time will be lost if there are interruptions to the power supply.</p> |
| Flowrate Input Failure | <p>The flowrate sensor (analog input) has failed.</p> <p>It is not possible to override this error condition. The instrument cannot operate without a flowrate input.</p> |
| No Flow Detected | <p>The no flow condition is detected when the flow timeout expires during a delivery. There must not be a period of no flow greater than the timeout value during the delivery.</p> |
| Overflow Detected | <p>The overflow condition is detected when the flow continues longer than the timeout period after the controller has attempted to stop the flow.</p> |
| Leakage Detected | <p>The leakage condition is detected when an amount greater than the acceptable total is received without flow being initiated by the batch controller.</p> |

Warning Messages

The system displays warning messages as described in the following table:

| Warning Messages | Description |
|--------------------------------|---|
| Value Has Been Set to Default | <p>You have entered an invalid value for a parameter. Therefore, the instrument has set the default value.</p> |
| Already Assigned to Other Port | <p>You have tried to assign a particular protocol type to more than one serial communication port. The instrument has set the protocol to NONE.</p> |
| Preset Over Limit - Max Set | <p>You have exceeded the preset limit. The instrument will set the maximum allowed value.</p> |

Chapter 6

Communications

Overview

This chapter describes the communications between the instrument and another communicating device such as a computer or a printer. You should have relevant information about the devices to which the instrument will be connected. Some connection examples are included in this manual, however, the operation and connection of other devices is outside the scope of this manual.

Hardware Interconnection

The instrument has three communication ports:

- RS-232 port on the rear panel (plus optional DB9 female connector)
- RS-485 port on the rear panel
- Infra-red port on the front panel (display panel option only)

The appropriate interface and protocols are selected during calibration.

RS-232 Port

The RS-232 port provides communication between the instrument and one other device such as a host computer or a printer.

Note: A printer must have a serial port to be able to be directly connected to the flow computer. It is not possible to communicate directly with a printer via a parallel port.

Computers use either a DB9 or a DB25 connector, and the connections to each type are shown in Figure 13.

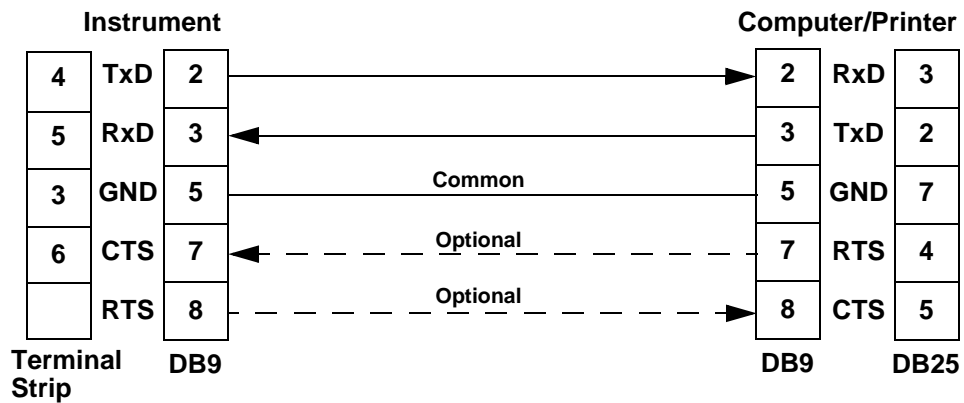

Figure 13 RS-232 Cable Connections to a Computer

Note: The instrument requires a cable with straight-through connections. Do not use a null modem cable for RS-232 connection to a computer.

RS-485 Port

The RS-485 port enables communication with multiple devices. Each device has a unique address so that the “master” device can communicate with specific “slave” devices.

On RS-485 links, an external terminating resistor must be connected at the furthest end of the cable. When multiple instruments are connected, they should be “daisy chained” in a multidrop configuration as shown in Figure 14. Up to 32 units can be connected to the interface at a maximum distance of 1200 metres.

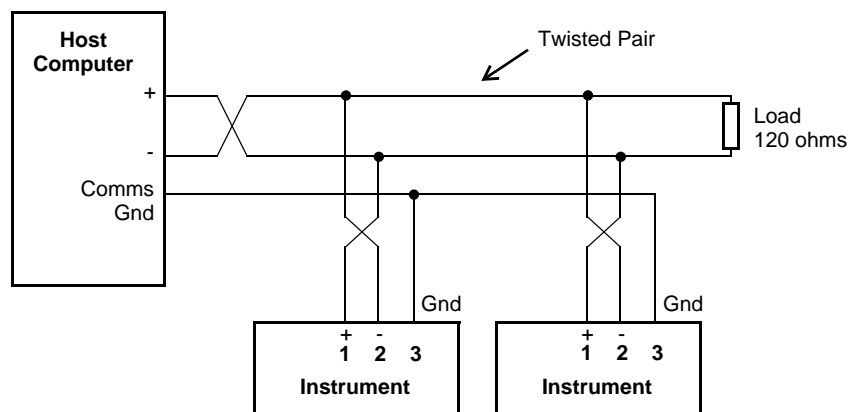

Figure 14 RS-485 Connections

Infra-red Port

The infra-red port is located on the front panel of the instrument. The infra-red port uses the Infra-red Developers Association (IrDA) physical layer format of signal encoding and decoding.

The nature of the infra-red port requires the communicating device to be located close to the front of the instrument. Therefore, its main use would probably be for reloading the instrument application software, or occasional collection of data, rather than continuous communications.

Protocols

Any of the ports on the instrument can use the ASCII or Modbus RTU communication protocols. The RS232 port can also be assigned the Printer Protocol.

- **ASCII** - In this ASCII protocol each command and response is a string of ASCII characters. This proprietary protocol is developed by Contrec to allow for simple information interchange. The main advantages of this mode are that it allows extended time intervals to occur between characters without causing a timeout error and that messages can be sent and monitored easily with a simple ASCII terminal.
- **Modbus RTU** - Modbus RTU is an industry-standard protocol which allows the instrument to be easily connected to computers running supervisory software systems. The main advantage of this mode is that its greater character density allows better data throughput than ASCII mode, however each message must be transmitted in a continuous stream.
- **Printer** - In the Printer protocol there is a selection of printer types. Please refer to the [Printer Protocol](#) on page 56 for full details.

Note: If a port is not being used, its protocol should be set to NONE in the instrument configuration as described in [Communications](#) on page 36.

A protocol cannot be assigned to more than one port. Therefore if you assign Modbus RTU protocol to the RS-485 port, you cannot assign it to the RS-232 port also. The RS-232 port can now only use the ASCII or Printer protocol or NONE.

Simple ASCII Protocol

Note: Not all ASCII commands are applicable for Batch Controller applications.

This simple ASCII protocol requires that all requests are initiated with a colon (:) and terminated with a carriage return (C_R). The message termination can include a linefeed before the carriage-return ($L_F C_R$), but it is the carriage-return that acts as the message termination.

All responses by the instrument are terminated with a linefeed and a carriage-return ($L_F C_R$).

Requests Format

The format of a request to the instrument is as follows:

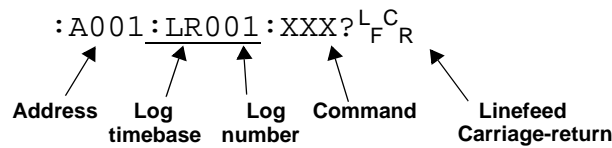

Each request must include the address and command portions. The underlined section is an optional part of the request string.

Address

In multipoint communications, each instrument must have a unique address and it is essential in the request for identifying a particular instrument. However, it may be set to 000, for special broadcast commands. For single-instrument communications, the address can also be set to 000 in the request.

Refer to [Communications](#) on page 36 for setting the instrument address.

Note: The instrument always responds with its address in the header regardless of the type of request.

Log Type and Number

The log type and number enables a communicating device to retrieve data from the instrument. The data can be from the event-based logs or from the current process variables with the either accumulated or non-accumulated (resettable) totals.

The log request is optional. If the log request is not included, or the log number is set to 000, the instrument returns the current process variables. If the log request is included, the log number defines the specific log entry by counting backwards. The most recent log entry for a timebase is 001.

The “last edit” log records the process variables at the time of the last exit from the calibration edit mode. There is only one “last edit” log, therefore, if a number is included in the request, the instrument ignores the number and returns the data at the time of the last edit. Likewise, there is only one set of current process variables with “non-accumulated totals”, therefore it also ignores any log number included in that request.

The types of the logs applicable to this instrument are as follows:

| Log Type |
|--|
| LE - last edit log |
| LR - logged records (non-timebased logging) |
| LN - current totals displayed as Non-accumulated |

The number of the log entry is the same as shown on the front panel of the instrument. For example, a request for LR003 would return the data for the log entry two batches prior to the most recent batch log entry.

Instrument Responses

The instrument response time to any enquiry is not more than 300ms. The responses from the instrument are in the following format:

```

HEADERLFCR
DATALFCR
DATALFCR
.
.
.
DATALFCR
LFCR
    
```

The components of the response message are as follows:

Header

The format of the response header from the instrument is as follows:

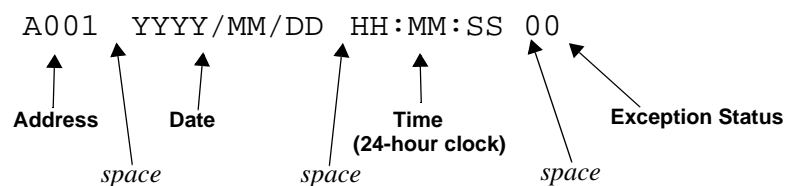

The instrument **Exception Status** codes that the instrument returns for the ASCII protocol are the same as those described for the Modbus RTU protocol in [Instrument Exception Status](#) on page 54.

Data

The format of the data variables from the instrument is as follows:

| | | | | | | | | | | | | | | | | | | | | | | | | | |
|-----------------------|---|---|---|---|---|---|---|-----|----|----|--------------|---------------------|----|----|----|----|----|--------------|---------------------|----|----|----|----|----|----|
| 8 9 1 2 3 . 4 5 6 | | | | | | | | M 3 | | | V O L U M E | | | | | | | | | | | | | | |
| 1 | 2 | 3 | 4 | 5 | 6 | 7 | 8 | 9 | 10 | 11 | 12 | 13 | 14 | 15 | 16 | 17 | 18 | 19 | 20 | 22 | 23 | 24 | 25 | 26 | 27 |
| Value (aligned right) | | | | | | | | | | | <i>space</i> | Unit (aligned left) | | | | | | <i>space</i> | Item (aligned left) | | | | | | |

Note: The decimal point in the Value is always at character position 8. Therefore whole numbers are aligned right at the decimal point, with trailing zeroes.

Variables Request

The variables request asks the instrument to return the value of one or more requested variables. All totals are transmitted as accumulated totals.

| Command | Description |
|--------------------|---|
| :RVA? | Return all variables |
| :RVD? | Return the default Total and Rate |
| :RV0? ... :RV9? | Return the specific variable. The numbers relate to the position in the variables menu. For example, V0 is Energy, V1 is Power and so on. |

Variables Request and Response Example

The following request is for the only instrument that is connected to the communication port to return the values of all main menu variables.

: A 0 0 1 : R V A ? L_F C_R

The following is an example of a hypothetical instrument response. Refer to [Main Menu Variables](#) on page 3 for the list of variables that would be returned for this application.

```

A 0 0 1   2 0 0 2 / 0 3 / 1 4   1 8 : 2 5 : 0 0   0 0 LF CR
          6 . 1 1 6   M W h           E N E R G Y   LF CR
          1 6 . 5 7 3   M W           P O W E R     LF CR
    1 3 2 0 . 5 3 0   m 3           V O L U M E   LF CR
          5 8 . 3 0 0   m 3 / M       V - F L O W   LF CR
    7 6 2 7 . 1 1 7   K G           M A S S       LF CR
          3 4 4 . 4 6 0   K G / M     M - F L O W   LF CR
          2 3 0 . 0 0 0   D E G   C   T E M P     LF CR
          1 . 2 6 0   M P A           P R E S S   LF CR
          0 . 1 7 4   m 3 / K G       S P - V O L   LF CR
    2 8 8 6 . 7 6 0   K J / K G       S P - E N T   LF CR
LF CR
    
```

The following message to an instrument, requests the current values for the default rate and total:

: A 0 0 1 : R V D ? L_F C_R

The instrument response would be similar to the following:

```
A 0 0 1 2 0 0 2 / 0 3 / 1 4 1 8 : 2 5 : 0 0 0 0 LF CR
      1 2 6 . 4 5 5 m 3 V O L U M E LF CR
      2 0 . 4 3 7 m 3 / M V - F L O W LF CR
LF CR
```

Log Request

The log request asks the instrument how many logs will be included in a printed log report. These are the values described in [Time Settings and Data Logging](#) on page 37.

| Command | Description |
|---------|---|
| :RLR? | Return the number of log records (non- timebased logging) |

Log Response Example

The following message asks the instrument with address 001 to return the number of hourly logs that the instrument stores:

```
: A 0 0 1 : R L R ? LF CR
```

The instrument response would be similar to the following:

```
A 0 0 1 2 0 0 2 / 0 3 / 1 4 1 8 : 2 5 : 0 0 0 0 LF CR
2 4 LF CR
LF CR
```

Clear Data Request

The clear data request asks the instrument to clear the data in the selected registers.

| Command | Description |
|---------|---|
| :RCN? | Clear the non-accumulated (resettable) totals |
| :RCA? | Clear the accumulated totals |
| :RCL? | Clear the logs except for the “last edited” log |

Clear Data Request Example

The following message asks the instrument with address 001 to clear the logged data that the instrument stores:

```
: A 0 0 1 : R C L ? LF CR
```

The instrument response would be similar to the following:

```
A 0 0 1 2 0 0 2 / 0 3 / 1 4 1 8 : 2 5 : 0 0 0 0 LF CR
LF CR
```

Instrument Information Request

The Instrument Information request asks the instrument to return the general information about the model and version codes. The instrument exception status is returned as a part of the header as it is with the header for all command responses.

| Command | Description |
|---------|--|
| :RIG? | Return the general information about the instrument such as Model number, Application number, Version and Serial numbers etc. These items are returned as a block in the same format as shown on the display in the “Model Info” menu. |

Instrument Information Response Example

The following message asks the instrument with address 001 to return the general information about the instrument:

```
: A 0 0 1 : R I G ? LF CR
```

The following is an example of a hypothetical instrument response:

```
A 0 0 1 2 0 0 2 / 0 3 / 1 4 1 8 : 2 5 : 0 0 0 0 LF CR
5 1 5 M O D E L - 1 1 - F - LF CR
S C 0 1 I N P U T F - T P - - LF CR
S C 0 1 V E R S 0 1 0 1 . 0 0 1 LF CR
C U S T O M V E R S 0 0 0 0 0 1 LF CR
U N I T S / N 1 2 3 4 5 6 LF CR
LF CR
```

| | | | | | | | | | | | | | | | | | | | | | | | | | | | | |
|---|---|---|---|---|---|---|---|---|----|----|----|----|----|----|----|----|----|----|----|----|----|----|----|----|----|----|----|----|
| 1 | 2 | 3 | 4 | 5 | 6 | 7 | 8 | 9 | 10 | 11 | 12 | 13 | 14 | 15 | 16 | 17 | 18 | 19 | 20 | 21 | 22 | 23 | 24 | 25 | 26 | 27 | 28 | 29 |
|---|---|---|---|---|---|---|---|---|----|----|----|----|----|----|----|----|----|----|----|----|----|----|----|----|----|----|----|----|

Corrupted or Invalid Requests

If the instrument receives a corrupted or incomplete request, there is no response. The instrument discards any partial request and waits for the next enquiry.

If the instrument receives a request message in the correct format, but for a non-existent option, it returns only the message header. For example, if the instrument received the following request variables message :A001:RVT? it will return only the header because there is no T option for the ‘Variables Request’ message.

Modbus RTU Protocol

Modbus RTU (remote terminal unit) is an industry standard protocol that allows the instrument to be easily interfaced to other communication devices.

The instrument implements the Modbus protocol as detailed in the *Modicon Modbus Protocol Reference Guide* PI-MBUS-300 Rev J (June 1996).

Message Format

In RTU mode, messages start with a silent interval of at least 3.5 character times. The first field transmitted is the device address. Following the last transmitted character, a similar interval of at least 3.5 character times marks the end of the message. A new message can begin after this interval. The entire message frame must be transmitted as a continuous stream. A typical message frame is shown below:

| Address | Function | Data | CRC Check |
|---------|----------|---------|-----------|
| 1 byte | 1 byte | n bytes | 2 bytes |

Except for broadcast messages, when a master device sends a query to a slave device, it expects a normal response. One of four possible events can occur from the master's query:

- If the slave device receives the query without a communication error, and can handle the query normally, it returns a normal response.
- If the slave does not receive the query due to a communication error, no response is returned. The master program has to process a timeout condition for the query.
- If the slave receives the query, but detects a communications error (parity or CRC), no response is returned. The master program has to process a timeout condition for the query.
- If the slave receives the query without a communication error, but cannot handle it (for example, if the request is to read a nonexistent register), the slave will return an exception response informing the master of the nature of the error.

Instrument Address

The address of the instrument is programmable in the range from 1 to 247. Some addresses are reserved according to PI-MBUS-300 and have a special meaning:

- 0 = Broadcast, no response required from slave devices
- 248 to 255 Reserved

Function Codes

The instrument accepts the following function codes:

| Code | Name | Description |
|------|-------------------------|--|
| 03 | Read data register(s) | Obtain the content of one or more 2-byte data registers. |
| 06 | Preset data register | Preset one 2-byte data register. |
| 07 | Read status register | Obtain the content of 1-byte status register. |
| 16 | Preset data register(s) | Preset one or more 2-byte data registers. |

Exception Response

The instrument forms an exception response by adding 80H to the function code and using an exception code as the 1-byte data field in the returned frame. Implemented exception codes are as follows:

| Code | Name | Description |
|------|----------------------|---|
| 01 | Illegal function | The function code is not a legal action for the slave. |
| 02 | Illegal data address | The data address is not a legal address for the slave. |
| 03 | Illegal data value | The data value is not a legal value for the slave. |
| 05 | Acknowledge | The slave has accepted the request and is processing it, but a long duration of time will be required to do so. |
| 06 | Slave device busy | The slave is engaged in processing a long duration program command. The master should re-transmit the message later when the slave is free. |

List of Data Registers

The following list describes the addresses and meaning of the data registers in the instrument. The floating point values are expressed in the engineering units that were selected for the variables when the instrument software was downloaded.

The registers are grouped in blocks that relate to a particular function of the instrument.

Note: Conventional numbering of registers often starts from 1, therefore be aware that “register 1” in this case has “address 0” and so on.

Current and Logged Process Data

This block of registers is available for the retrieval of current or logged process data with its matching time and date information.

Use the log timebase and log number to retrieve the logged information from the appropriate register. If a particular log number does not exist, or the instrument does not have the optional real-time clock, the time and date stamp and associated variables are set to zero.

| Register | Name | Comments | Read Only or Read/Write | Type |
|----------|------------|---|-------------------------|------|
| 1 | Volume | <p style="text-align: center;">Process Variables</p> <p>By default totals are the Accumulated values. If current Non-accumulated (resettable) totals are required, set register 37 to 06. All logged totals are the Accumulated values.</p> | R | FP* |
| 3 | Reserved | | R | FP |
| 5 | Reserved | | R | FP |
| 7 | Reserved | | R | FP |
| 9 | Reserved | | R | FP |
| 11 | Reserved | | R | FP |
| 13 | Reserved | | R | FP |
| 15 | Reserved | | R | FP |
| 17 | Reserved | | R | FP |
| 19 | Reserved | | R | FP |
| 21 | Reserved | | R | FP |
| 23 | Reserved | | R | FP |
| 25 | Reserved | | R | FP |
| 27 | Reserved | | R | FP |
| 29 | Reserved | | R | FP |
| 31 | Year | <p>Current Date/Time or Logged Date/Time Stamp (see register 38 Log Number). Only current Date/Time can be edited</p> | R/W | I† |
| 32 | Month | | R/W | I |
| 33 | Date | | R/W | I |
| 34 | Hour | | R/W | I |
| 35 | Minute | | R/W | I |
| 36 | Second | | R | I |
| 37 | Log Type | <p>00 - hourly or log records 01 - daily 02 - weekly 03 - monthly 04 - yearly 05 - last edit of calibration 06 - current totals are non-accumulated values, register 38 is ignored.</p> | R/W | I |
| 38 | Log Number | If set to 0, current variables and Date/Time are retrieved | R/W | I |

| Register | Name | Comments | Read Only or Read/Write | Type |
|----------|------------|---|-------------------------|------|
| 39 | Clear Data | 01 - clear logs 02 - clear accumulated totals 03 - clear non-accumulated totals | W | |
| 40 | Reserved | | R/W | |

* FP = Floating Point (2 registers = 4 bytes)

† I = Integer (2 bytes) (Holding Registers)

Note: The Floating Point variable is represented in IEEE-754 Floating Point 4-byte format and requires two 2-byte data registers:

| IEEE-754 | Modicon Registers |
|----------|--------------------------|
| 1st byte | low byte (register X) |
| 2nd byte | high byte (register X) |
| 3rd byte | low byte (register X+1) |
| 4th byte | high byte (register X+1) |

This means that two data registers must be read or written to obtain, or preset, one data value.

Instrument Exception Status

This register is available to verify the status of the instrument.

| Register | Name | Comments | Read Only or Read/Write | Type |
|----------|------------------|--|-------------------------|------|
| 41 | Exception Status | 00 = no error 01 = analog input 1 failure 02 = analog input 2 failure 03 = analog input 3 failure 04 = analog input 4 failure 05 = invalid calibration parameter 06 = invalid reference parameter 07 = invalid property 08 to 09 reserved 10 = process parameters out of range 11 = input is over limit 12 = no flow error detected 13 = overflow error detected 14 = leakage error detected 20 = system failure 21 = power supply is low 22 = new or failed clock battery | R | I* |

* I = Integer (2 bytes) (Holding Registers)

Instrument Configuration, Control and I/O

This block of registers is available in some applications to give access to important information in the instrument.

| Register | Name | Comments | Read Only or Read/Write | Type |
|----------|------------------------|---|----------------------------------|------|
| 42 | Parameter Source | 0 = User 1 = Modbus | R | I* |
| 43 | Reserved | | | |
| 44 | Operation State | Representation of operation status 0 = Reset 1 = Maintenance 2 = Completed 3 = Waiting to restart 4 = Paused 5 = Waiting for timeout 6 = Running (Slow Start) 7 = Running (Prestop) 8 = Running (Full Flow) | R | I |
| 45 | Reserved | | | |
| 50 | Control Mode | 0 = Idle/Local Control from logic inputs 1 = Stop Suspend current batch 2 = Run Resume/start batch 3 = Reset Clear current batch totals | R/W | I |
| 51 to 99 | Calibration parameters | This bank of registers gives access to the control set point values in the same order as described within Parameters on page 29. The accessible values are those items immediately following the parameter items that sets the access as either USER or RTU. | R if 42 = 0 R/W if 42 = 1 | FP† |
| 101 | Analog Input | The input is configured for 4-20mA. The value will be read in Amperes. | R | FP |

* I = Integer (2 bytes) (Holding Registers)

† FP = Floating Point (2 register = 4 bytes)

Printer Protocol

A printer protocol is available in the 500 Series. It provides the ability to print out live data, individual logged data and to do some report-style printing of logged data. The method of printing these and the format of the printouts is described below.

Note: Printer output is only available if the Real Time Clock option is fitted and is only available on the RS232 communications port.

The selection of Printer Protocol can be made for the Communications Protocol options for the RS232 port. A list of log report types and printer types available at the end of the TM-LOG calibration menu.

Report Types

The list of report types is as follows:

- REP-10 Latest Logs Report

The number of logs printed in each report are determined by the values programmed for Report Logs in the TM-LOG menu.

Printer Types

The list of available printers is as follows:

- PRN-01 Generic computer printer
- PRN-02 Generic roll printer (printing first line first)
- PRN-03 Slip Printer TM295

Customizing a Printout

A customized printout can be provided which can have up to 4 header lines and 3 footer lines. It is also possible to include or exclude each main menu items on the printout. If any customizing of the printout is required discuss this with the distributor.

Types of Printouts

Live Data

The RESET key, when in main menu, is shared as the PRINT key if the printer protocol has been selected. A printout will be initiated whenever this key is pressed. If printing is not required, do not select printer protocol.

The format of this printout will be:

Custom Header Line 1
Custom Header Line 2
Custom Header Line 3
Custom Header Line 4

Current Docket No.

Instrument Serial No. & Tag

Current Date & Time & Status
Variable unit value
Variable unit value
Variable unit value
etc.

Custom Footer Line 1
Custom Footer Line 2
Custom Footer Line 3

----- <separation line>

(Note that blank header and footer lines are not printed).

Docket Number

The docket number that appears on the live data printout indicates the print number. This number is cleared when the Accumulated totals are reset. If the Reset Mode is set for Delayed, where a print can be generated without resetting the non-accumulated totals, an additional number in brackets will be shown that indicates the number of prints since the last reset. i.e.

DOCKET No. 000256 (000036)

Instrument Serial Number and Unit Tag

The instrument serial number and unit tag is the same as the information shown in the Model Info menu. For more details refer to **Model Information** on page 19

Individual Log Data

When in the Log Menu and while holding the DISPLAY key to view the data of the log of interest the RESET key can be pressed to initiate a printout of that log entry. The printout will have the time and date stamp corresponding to when the log was taken. After the print has been initiated there will be the opportunity to scroll to view another log entry and print again.

Since each log entry stores the delivery totals only, the printout will not have any accumulated totals. The format of the printout with this exception is the same as the LIVE DATA printout:

Custom Header Lines

Instrument Serial No. & Tag

Delivery No. Date & Time & Status

Variable unit value

Variable unit value

Variable unit value

etc.

Custom Footer Lines

----- <separation line>

Log Report Printing

As there is the likelihood that the reports can be of a considerable length it is strongly recommended that only the 80 Column printer with Z fold (tractor feed) paper be used. This is just as much for the memory storage of printer as it is for the reliable paper supply.

There is a HOLD.SET REPORT PRINT prompt under the main menu with the ability to print the pre-selected type of report. Pressing and holding the SET key for two seconds will initiate the printout. Any of the Log Reports will have the following format:

Custom Header Lines

Title of Report <internally set, indicates report type>

Current Date & Time

Instrument Serial No. & Tag

----- <separation line>

Delivery No. Date & Time & Status

Variable unit value

Variable unit value

Variable unit value

etc.

----- <separation line>

Delivery No. Date & Time & Status

Variable unit value

Variable unit value

Variable unit value

etc.

----- <separation line>

Delivery No. Date & Time & Status

Variable unit value

Variable unit value

Variable unit value

ETC

Custom Footer Lines

----- <separation line>

Reports such as “Latest Logs” will print in the historical order, and for those logs that have no data (e.g. unit was powered off at the time) the print will show “Data not available”. i.e.

----- <separation line>

Del No. Data Not Available

----- <separation line>

Delivery No. Date & Time & Status

Variable unit value

Variable unit value

Variable unit value

etc.

If the unit is programmed for 0 logs for the latest log reports then the report will only consist of the header and ID information and a “Data Not Available” message.

Custom Header Lines

Title of Report

Current Date & Time

Instrument Serial No. & Tag

Data Not Available

Custom Footer Lines

----- <separation line>

Printer Data Control

Some printers have limited data buffers and are therefore unable to collect all the print data being transmitted. The 500 Series has the capability of software handshaking. The Xon/Xoff characters can be used by any of the printer types to control the flow of data to ensure that data is not lost.

Some printers will also transmit an Xoff character in response to other events such as printer being off-line, print head not engaged or power being removed. The specific behaviour of the printer being used should be noted.

Error Messages

There are two printer error messages that can be displayed.

PAPER OUT

This message is related to the Printer Type PRN-03 TM295 Slip printer. It is standard procedure with this printer to check for paper status before printing. If a print is attempted but there is no paper the PAPER OUT message will be scrolled. The instrument will continue to poll the printer for paper and if paper is detected before a communications timeout expires the print will commence.

COMMS TIMEOUT

This message is relevant for all printer types and will be activated for the following conditions.

1. If the flow of data is stopped due to software or hardware handshaking and is not allowed to resume before the communications timeout.
2. If Printer Type is PRN-03 Slip printer and a paper status is requested but no response is received within the timeout period.
3. Paper Out has been detected for Printer Type PRN-03 but no paper is inserted within the timeout period.

When a communications timeout error has been activated the message COMMS TIMEOUT will be scrolled once, the request to print will be cleared and the instrument will return to its normal mode.

Appendix A

Model Numbers

Product Codes

| Model | Supplementary Code | | Description |
|--|--------------------|--|---|
| 505 | - BC02 | | |
| Enclosure | 1 | | Panel mount enclosure |
| | 2 | | Field mount enclosure (not yet available) |
| | 3/5 | | Explosion proof Ex410 with metric glands (5 specifies heater version) |
| | 4/6 | | Explosion proof Ex410 with NPT glands (6 specifies heater version) |
| Output Options | 0 | | Basic - RS232 and RS485 serial ports, 2 relays, 2 pulse outputs, rear key input |
| | 1 | | Advanced - also includes 4-20mA o/p and Real-time clock for printer output and logging (100 logs) |
| Extra Options | 2 | | 9-way DB connector for RS232 serial port |
| Power Supply | E | | For 220/240VAC |
| | A | | For 110/120VAC |
| | D | | For DC power only 12-28VDC |
| Display Panel Options | S | | Standard (no backlight, LCD backup or Infra-Red comms port) |
| | F | | Fully optioned (with backlight, LCD backup and Infra-Red comms port) |
| PCB Protection | C | | Conformal coating - required for maximum environmental operating range. Recommended to avoid damage from moisture and corrosion. |
| | N | | None - suitable for IEC standard 654-1 Climatic Conditions up to Class B2 (Heated and/or cooled enclosed locations) |
| Application Pack Number | BC02 | | Defines the application software to be loaded into the instrument |
| For example: Model No. 505.112EFC Displayed on the 500 Series as: (only h/w that affects the operation is represented) | | | - I - - F - 505 MODEL |

Note: Example full product part number is 505.112EFC-BC02 (This is the number used for placing orders).

Custom Version Codes

| | Code | | Description |
|--|------|--|---|
| Origin Code Identifies Distributor | 00 | | Factory Default Application |
| | 01 | | Contrec Pty. Ltd. Melbourne Australia |
| | 02 | | Contrec Pty. Ltd. Sydney Australia |
| | 03 | | Contrec Europe Ltd. West Yorkshire UK |
| | 04 | | Contrec - USA, LLC. Pelham AL 35124 USA |
| | 05 | | Flowquip Ltd. Halifax UK |
| | 06 | | |
| | etc. | | |
| User Language | 0 | | English (Default) |
| | 1 | | German |
| | 2 | | Dutch |
| | 3 | | French |
| | 4 | | Spanish |
| | 5 | | |
| | etc. | | |
| Distributor's Code | 000 | | Distributor's own choice. Possibly a code that identifies the customer and the application. |
| | ... | | |
| | 999 | | |
| For example: 02 3 157 Displayed on the 500 Series as: | | | 023 157 CUSTOM VERS |

Application Information Code

The Application Information code is an aid for users and service personnel to determine the type of inputs that are used in a particular application. The Application Information code is displayed on the instrument as shown below.

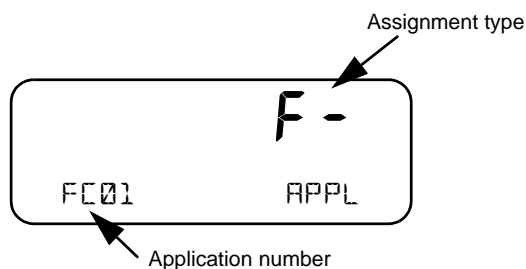

The Application Information code is returned as part of a General Instrument request (as described in [Instrument Information Request](#) on page 50).

The Application number identifies the application as in the following examples:

- BC01 - single channel batch controller for frequency flow input.
- FC01 - single channel flow computer for frequency flow input

The Input Assignment type indicates the physical input that is assigned to each input on the instrument. The code is made up from two characters as follows:

| FINP | AINP |
|-------------|-------------|
| X | X |

The codes are as follows:

- - - not used in this application
- *A* - indicates an analog flow input such as for volume or mass
- *F* - indicates a frequency flow input such as for volume or mass
- *L* - indicates a level input
- *d* - indicates a density input
- *t* - indicates a temperature input.

For example, *FL* is an instrument with FINP (frequency input) assigned to a flow input, AINP (analog input) assigned to a level input.

Appendix B

Units of Measurement

Available Units of Measurement

The following is a list of the available units of measurement used across the range of 500 Series applications.

| Units Type | Available units of measurement |
|-------------------|---|
| Volume | m ³ , Km ³ , Ltr, Gal, KGal, MGal, ft ³ , kft ³ , Mft ³ , bbl |
| Volume Flowrate | m ³ /s, m ³ /min, m ³ /h, m ³ /D, L/s, L/min, L/h, Gal/s, Gal/min, Gal/h, KGal/D, MGal/D, ft ³ /s, ft ³ /min, ft ³ /h, Mft ³ /D, bbl/s, bbl/min, bbl/h, bbl/D |
| Volume K-Factor | P/m ³ , P/Ltr, P/Gal, P/ft ³ , P/bbl |
| Mass | kg, g, Ton, lb, Klb |
| Mass Flowrate | kg/s, kg/min, kg/h, g/s, g/min, g/h, Ton/min, Ton/h, Ton/D, lb/s, lb/min, lb/h, Klb/min, Klb/h, Klb/D |
| Mass K-Factor | P/kg, P/g, P/Ton, P/lb, P/Klb |
| Energy | kJ, MJ, GJ, kWh, MWh, kBTU, Ton.h, therm, cal, kcal, Mcal |
| Power | kJ/h, MJ/h, GJ/h, kW, MW, kBT/M, kBT/h, Ton, therm/min, therm/h, kcal/h, Mcal/h |
| Energy K-Factor | P/kJ, P/kWh, P/kBTU, P/Ton.h, P/therm, P/kcal |
| Temperature | Deg K, Deg C, Deg F, Deg R |
| Pressure | Pa, kg/m ² , kg/cm ² , kPa, MPa, mbar, bar, psi, Atm, inH ₂ O, mmH ₂ O |
| Density | kg/m ³ , kg/Ltr, lb/ft ³ , SG60F |
| Specific Volume | m ³ /kg, L/kg, ft ³ /lb |
| Specific Enthalpy | kJ/kg, BT/lb, cal/g, cal/kg, kcal/kg, Mcal/kg |
| Reynolds Number | E+0, E+3, E+6 (scaling for unitless variable) |
| Length (Level) | m, mm, cm, INCH, FOOT |
| Velocity | m/s, m/M, m/h,ft/s, ft/M, ft/h |
| Length K-Factor | P/m, P/cm, P/INCH, P/FOOT |
| Area | m ² , ft ² |
| Ratio | % |

Index

Numerics

4-20mA

input 9

output 10

A

address, instrument 46

analog input

connections 9

scaling 2

application code 62

approvals 4

ASCII protocol 45

B

back panel 8

batch

errors 20

operations 21

start 19

stop 20

BATCH key 16

batch limit 17

batch preset

common values 17

batch processes 21

battery

failed 42

life 37

new 42

baud rate 36

C

calibration

menu 26

set mode 24

view mode 23

clock

battery 37

date format 38

real-time 37

codes

application information 62

customer version 62

exception 54

product number 61

common preset values 17

communication

connections 12

protocols 45

communications 3, 43

menu 36

connections

communication 43

communications 12

control relays 11

electrical 8

input 9

output 10

customer version codes 62

customizing a printout 56

D

data log

viewing 17, 18

date format 38

default variable 15

digital output 11

display

specifications 5

timeout mode 39

timeout time 39

DISPLAY key 16

display-only parameter 23

E

earthing 14

edit batch preset 17

electrical connections 8

error messages 41

exception codes 54

Exception Status 47

F

- features 1
- flash driver port assignment 37
- format, date 38
- front panel 15
 - infra-red port 13
 - keys 16
 - lamps 15

G

- general specifications 5

H

- hardware connections 43

I

- infra-red port 13, 36, 44
- input
 - 4-20mA 9
 - connections 9
 - analog 9
 - specifications 5
- inputs menu 31
- installation 7
- instrument
 - address 46
 - request format 46
 - responses 47
 - settings 28
- interconnections, communication 43
- interference suppression 12

K

- key
 - BATCH 16
 - DISPLAY 16
 - RESET 16
 - RUN 16
 - SET 17
 - STOP 16
 - TOTAL 16
- keys, front panel 16

L

- lamps, status 15
- logged data 17
 - viewing 18
- logic input control 20

M

- main menu items 16
- menu
 - calibration 26
 - comms 36
 - inputs 31
 - outputs 34
 - params 29
 - setup 39
 - test 40
 - tm/log 37
 - units 28
- messages
 - error 41
 - system 41
 - warning 42
- Modbus RTU protocol 51
- mode
 - display timeout 39
 - set calibration 24
 - view calibration 23
- model numbers 61
- mounting 7

N

- number
 - model 61
 - serial 19

O

- operation, front panel 15
- output
 - connections 10
 - 4-20mA 10
 - digital 11
 - pulse factor 35
 - specifications 5
- outputs menu 34

P

- panel
 - lamps 15
 - mounting 7
 - rear 8
- parameter
 - display-only 23
 - not visible 23
 - password-protected 23
 - programmable 23

- parameters menu 29
- parity bits 36
- password-protected parameter 23
- port
 - assignment, flash driver 37
 - flash driver assignment 37
 - infra-red 13, 36, 44
 - RS-232 12, 36, 43
 - RS-485 13, 36, 44
- power supply interruption 37
- preset batch value 17
- printer
 - data control 59
 - error messages 60
 - protocol 56
 - report types 56
- printer types 56
- printouts
 - individual logs 57
 - live data 56
 - log report 58
 - types 56
- product number codes 61
- programmable parameters 23
- protocol
 - ASCII 45
 - communication 45
 - Modbus RTU 51
 - printer 56
- pulse factor, output 35

- R**
- real-time clock 37
- rear panel 8
- relay
 - connection 11
- relay outputs 3
- remote control 20
- RESET key 16
- responses, instrument 47
- RS-232 port 12, 36, 43
- RS-485 port 13, 36, 44
- RTU protocol 51
- RUN key 16

- S**
- scaling analog input 2
- serial number 19
- SET key 17

- settings
 - instrument 28
- setup menu 39
- shielding 14
- snubber 12
- specifications 5
- standards 4
- starting a batch 19
- status lamps 15
- stop bits 36
- STOP key 16
- stopping a batch 20
- suppression, interference 12
- system
 - errors 41
 - messages 41
 - warnings 42

- T**
- terminal designations 8
- test menu 40
- timeout
 - mode 39
 - time 39
- tm/log menu 37
- TOTAL key 16

- U**
- unit tag 19
- units
 - menu 28

- V**
- variable, default 15
- version, customer 62
- view data logs 17, 18

- W**
- warnings 42